

# 18.434- CADEIRA CELINA

Celina Chair  
Silla Celina



## ESQUEMA DE MONTAGEM PARA MONTAR UMA CADEIRA

Assembly manual for mounting 1 chair / Manual de montaje para montaje 1 silla

Vista Explodida: | Detalle de las piezas: | Parts detail:



ESPALDAR  
Handle/Manija

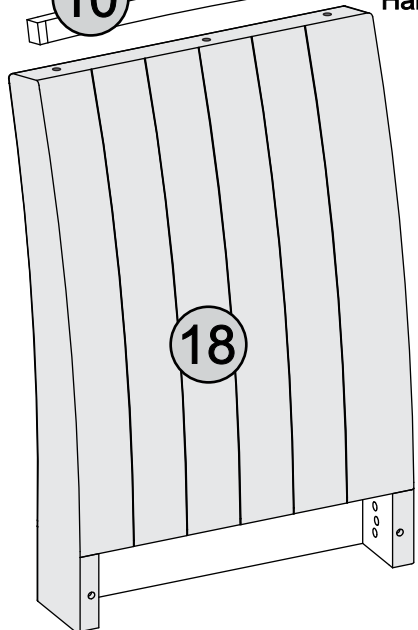

ENCOSTO MONTADO/  
TAPEÇADO  
Backrest mounted / tapered  
Respaldo Montado / Cubierto

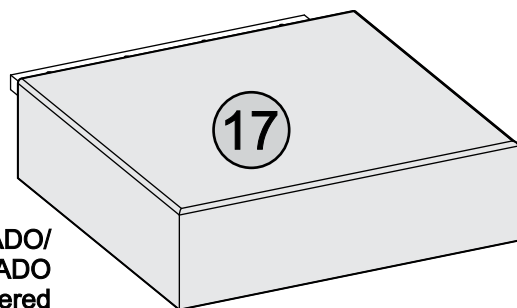

ASSENTO MONTADO/  
TAPEÇADO  
Seat Mounted / Covered  
Asiento Montado / Cubierto

PEÇAS SEPARADAS  
Separate parts  
Piezas separadas

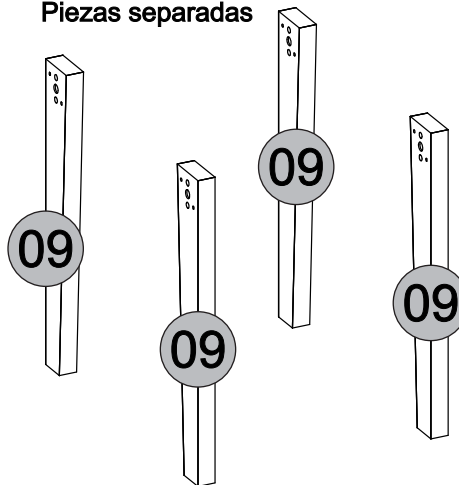

ENTENDENDO OS CÓDIGOS  
UNDERSTANDING THE CODES  
ENTENDIENDO LOS CÓDIGOS

1293|003  
Cód. da peça  
Piece code  
Part code

CÓDIGOS DAS CORES:  
COLOR SUBTITLE:  
LEYENDA DE COLORES:

09 - Rústico Malbec  
32 - Demolição  
49 - Rústico Terrara  
51 - Carvalho Americano  
05 - Suede Pena Marrom  
06 - Suede Pena Bege  
10 - Linho Claro  
11 - Linho Bronze  
14 - Linho Saara  
15 - Veludo Kraft

Nº	09	10	18	17
PEÇAS	PÉ FRONTAL /TRASEIRO	ESPALDAR	ENCOSTO MONTADO TAPEÇADO	ASSENTO MONTADO TAPEÇADO
PARTS	FRONT / REAR FOOT	HANDLE	TAPERED MOUNTED BACKREST	TAPARED MOUNTED SEAT
PIEZAS	PIE FRONTAL / TRASERO	MANIJA	RESPALDO MONTADO TAPIZADO	ASIENTO MONTADO TAPIZADO
CÓD. PEÇA/ PIECE CODE/ CÓD. PIEZA	18570	18571	18519	18520
DEMOLIÇÃO SUEDE PENA BEGE	32	32	06	06
DEMOLIÇÃO SUEDE PENA MARROM	32	32	05	05
DEMOLIÇÃO LINHO BRONZE	32	32	11	11
DEMOLIÇÃO LINHO CLARO	32	32	10	10
DEMOLIÇÃO LINHO SAARA	32	32	14	14
DEMOLIÇÃO VELUDO KRAFT	32	32	15	15
RUST. MALBEC SUEDE PENA BEGE	09	09	06	06
RUST. MALBEC SUEDE PENA MARROM	09	09	05	05
RUST. MALBEC LINHO BRONZE	09	09	11	11
RUST. MALBEC LINHO CLARO	09	09	10	10
RUST. MALBEC LINHO SAARA	09	09	14	14
RUST. MALBEC VELUDO KRAFT	09	09	15	15
RÚSTICO TERRARA PENA BEGE	49	49	06	06
RÚSTICO TERRARA PENA MARROM	49	49	05	05
RÚSTICO TERRARA LINHO BRONZE	49	49	11	11
RÚSTICO TERRARA LINHO CLARO	49	49	10	10
RÚSTICO TERRARA LINHO SAARA	49	49	14	14
RÚSTICO TERRARA VELUDO KRAFT	49	49	15	15
CARVALHO AMERICANO SUEDE PENA BEGE	51	51	06	06
CARVALHO AMERICANO SUEDE PENA MARROM	51	51	05	05
CARVALHO AMERICANO LINHO BRONZE	51	51	11	11
CARVALHO AMERICANO LINHO CLARO	51	51	10	10
CARVALHO AMERICANO LINHO SAARA	51	51	14	14
CARVALHO AMERICANO VELUDO KRAFT	51	51	15	15
FIBRA/ FIBER/ FIBRA	MDF	MDF	-	-
MEDIDAS (mm) MEASURES (mm) MEDIDAS (mm)	436x60x25	436x60x25	640x420x85	469x420x120
QTD	04	04	01	01

### Instruções para a montagem do produto:

Instructions for mounting the product  
Instrucciones para el montaje del producto



Separar as peças e acessórios de maneira organizada.  
Separate the parts and accessories in an organized way.  
Separar las piezas y accesorios de forma organizada



Forrar o chão com o papelão das embalagens.  
Cover the floor with the cardboard from the pack.  
Cubrir el suelo con el papelón de los embalajes.



É necessário uma pessoa para montar o produto.  
It's necessary one person to assembly the product.  
Se requiere una persona para montar el producto.

### Ferramentas necessárias

(não fornecidas)  
Required tools (not supplied)  
Herramientas necesarias (no incluidas)

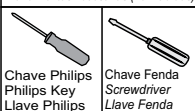

Chave Philips  
Phillips Key  
Llave Philips

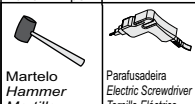

Martelo  
Hammer  
Martillo

Parafusadeira  
Electric Screwdriver  
Tornillo Eléctrico

### Cuidados para conservação e limpeza do móvel:

Cleaning and care of furniture:  
Cuidados para la conservación y la limpieza del mueble



Não molhar o móvel e não expor em lugar úmido.  
Do not moisten the furniture and not to expose in moist places.  
No moje el mueble y no ponga en local humedo.



Não usar produtos abrasivos.  
Do not use abrasive products.  
No utilice productos abrasivos.



Não expor o móvel próximo de fontes de calor.  
Do not expose furniture next to heat sources.  
No exponga el mueble cerca de fuentes emitan calor.



Limpe com flanela limpa e seca.  
For cleaning use a clean and dry cloth.  
Limpe con franela limpia e seca.

## ATENÇÃO/ ATTENTION/ ATENCIÓN

**PRAZO DE 24 HORAS PARA A SECAGEM DA COLA E USO DA CADEIRA. ANTES DESSE PRAZO NÃO UTILIZAR OU FORÇAR A CADEIRA, BEM COMO SEUS PÉS.**

**24 HOUR PERIOD FOR DRYING THE TAII AND USING THE CHAIR. BEFORE THAT DEADLINE DO NOT USE OR STRENGTHEN THE CHAIR, AS WELL AS ITS FEET.**

**PLAZO DE 24 HORAS PARA EL SECADO DE LA COLA Y USO DE LA SILLA. ANTES DE ESTE PLAZO NO UTILIZAR O FORZAR LA SILLON, BIEN COMO SUS PIES.**

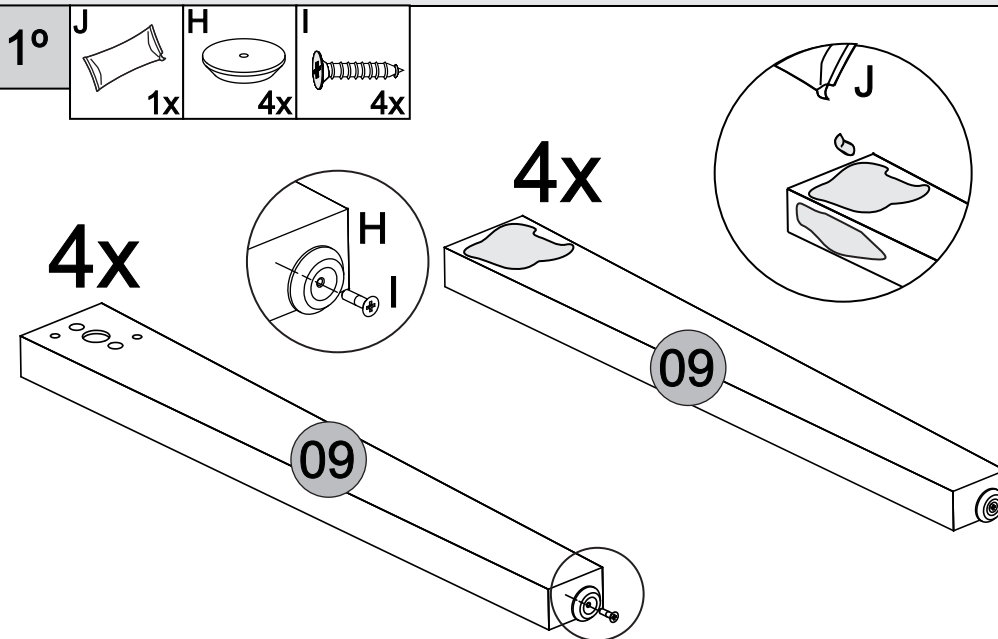

Aplique a cola em toda o lado do pé, conforme ilustração.

Apply glue to the entire side of the foot, as shown.

Aplique el pegamento en todo el lado del pie, según la ilustración.

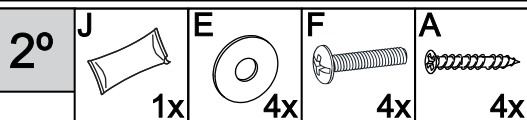

Aplique a cola nas laterais e na frente do assento, onde a lateral e o topo do pé será encaixado.

Apply the glue to the sides and front of the seat, where the side and back of the foot will be engaged.

Aplique la cola en los laterales y delante del asiento, donde el lateral y el respaldo del pie será encajado.

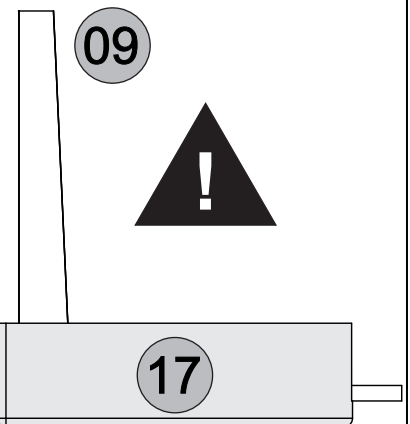
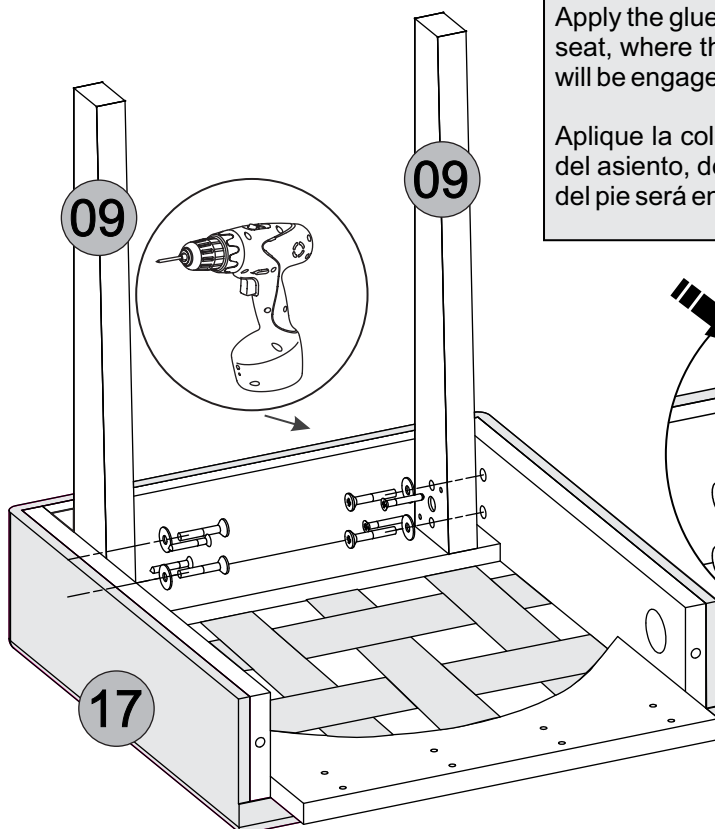

**ATENÇÃO** à posição do pé. O lado reto do pé **SEMPRE** deve estar encostado no lado frontal do assento.

**ATTENTION** to the foot position. The straight side of the foot should **ALWAYS** be leaning against the front side of the seat.

**ATENCIÓN** a la posición del pie. El lado recto del pie **SIEMPRE** debe estar apoyado en el lado frontal del asiento.

# 18.434 - CADEIRA CELINA

Celina Chair  
Silla Celina

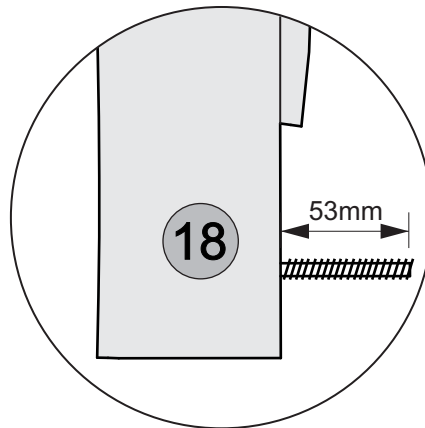
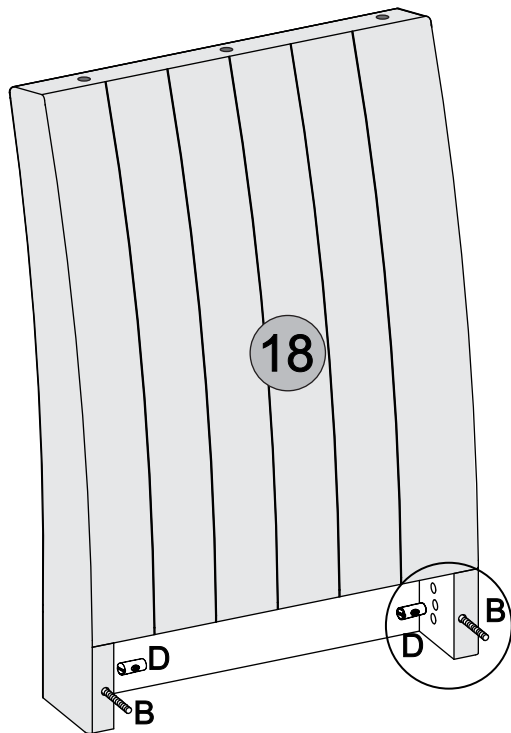
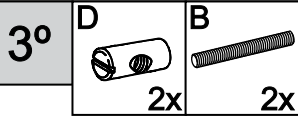

1° - Encaixe a porca cilíndrica (D) na furação do encosto.  
2° - Rosqueie a barra rosçada (B) na porca cilíndrica (D) conforme ilustração ao lado.

1st - Fit the cylindrical nut (D) into the hole in the backrest.  
2 - Thread the threaded rod (B) on the cylindrical nut (D) as shown in the illustration.

1 - Enganche la tuerca cilíndrica (D) en la perforación del respaldo.  
2° - Rosque la barra rosçada (B) en la tuerca cilíndrica (D) como ilustración al lado.

Ao fixar as Porcas Cilíndricas (D) deixar o encaixe da chave para fora, como mostra o desenho abaixo.

When fixing the Cylindrical Nuts (D) leave the key locking out, as shown in the drawing.



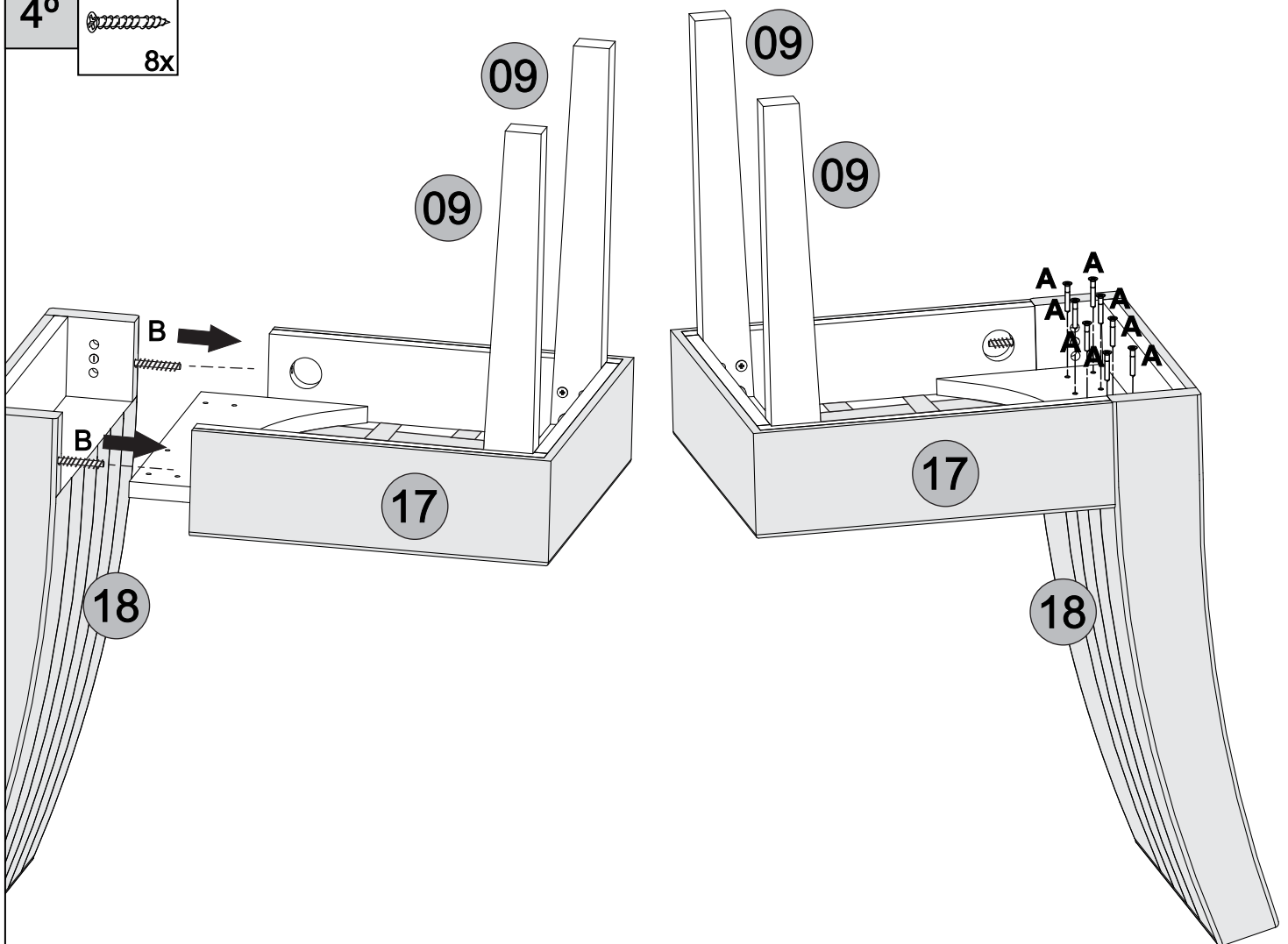
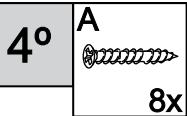
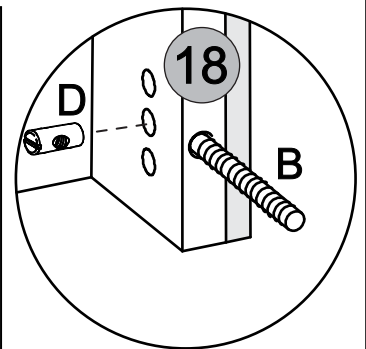

Al fijar las Tuercas Cilíndricas (D) dejar el encaje de la llave hacia fuera, como muestra el dibujo abajo.



# 18.434 - CADEIRA CELINA

Celina Chair  
Silla Celina



- 5°**
- A**  
  
 4x
  - J**  
  
 1x
  - E**  
  
 4x
  - F**  
  
 4x



**ATENÇÃO** à posição do pé. O lado reto do pé SEMPRE deve estar alinhado no encosto. Aplique a cola nas laterais e na traseira do encosto, onde a lateral e o topo do pé será encaixado.

**ATTENTION** to the foot position. The straight side of the foot should ALWAYS be aligned on the backrest. Apply the glue on the sides and back of the backrest, where the side and top of the foot will fit.

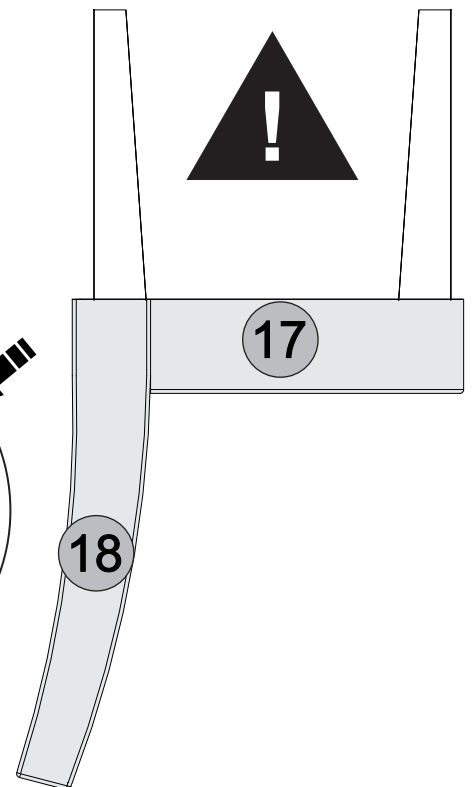
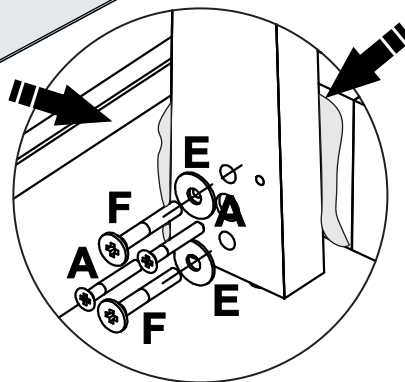
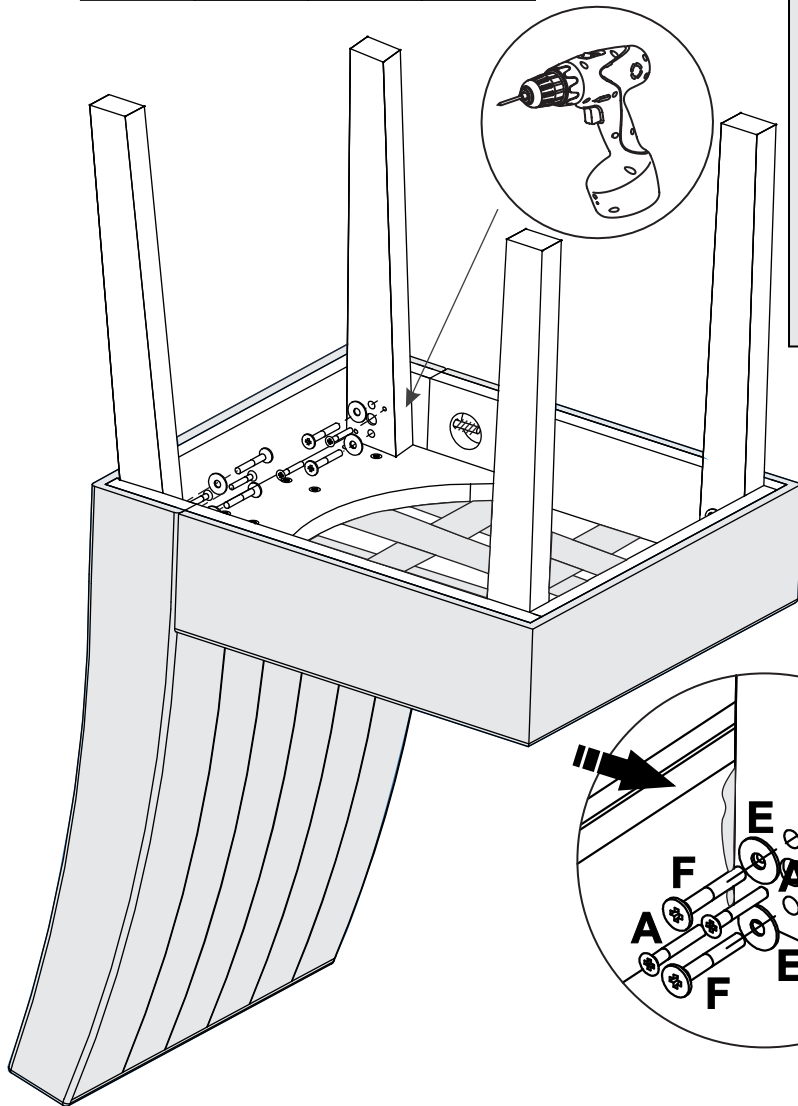
**ATENCIÓN** a la posición del pie. El lado recto del pie SIEMPRE debe estar alineado en el respaldo. Aplique la cola en los laterales y en la parte trasera del respaldo, donde el lateral y la parte superior del pie será encajado.



**6°**

- M**  
  
 2x
- C**  
  
 2x
- G**  
  
 1x

Chave de boca  
Wrench  
Llave de boca  
11mm

Com o auxílio da Chave de Boca (G), aperte a porca sextavada (M) até chegar à Porca Meia Lua (C)

With the help of the Wrench (G), tighten the hexagonal nut (M) until reach the half moon nut (C).

Con la ayuda de la Llave de Boca (G), apriete la tuerca hexagonal (M) hasta llegar a la Tuerca Media Luna (C)

- C**  
 Porca Meia Lua  
Half Moon Nut  
Tuerca Media Luna  
30 X 8.5
- B**  
 Barra Roscada  
Threaded Rod  
Barra Roscada  
90mm x 1/4
- M**  
 Porca Sextavada hexagonal nut  
Tuerca hexagonal  
1/4 x 7/16

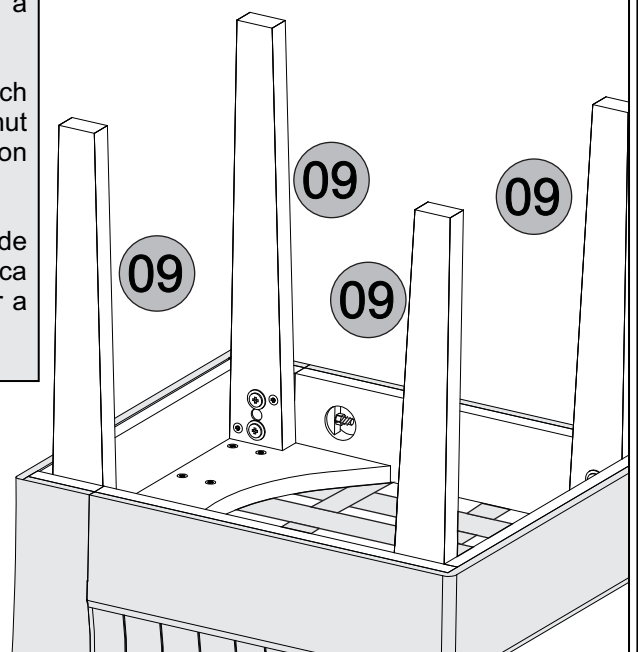
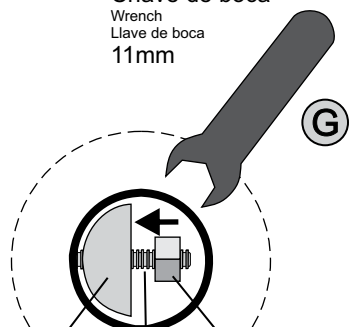

7°  
K  
12x

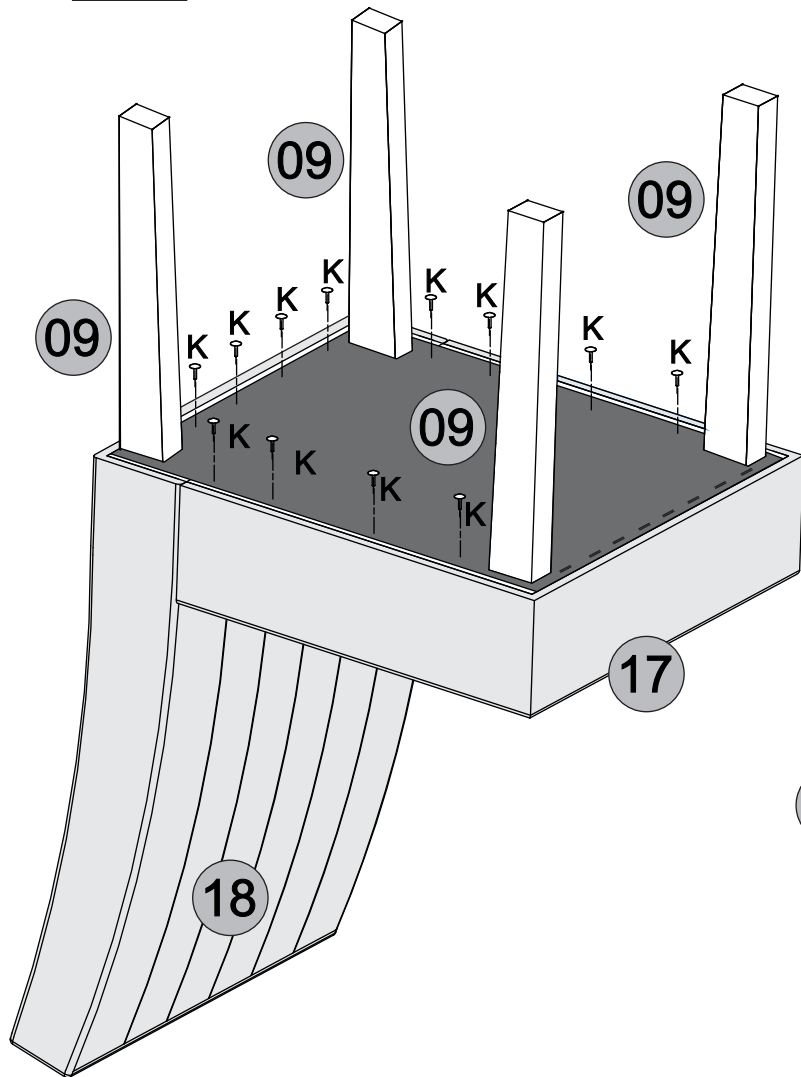

Aplique as tachas de ferro (K) sobre o TNT preto, já previamente grampeado na parte frontal do assento, finalizando a fixação nas laterais e traseiro do encosto.

Apply the iron tacks (K) on the black TNT, already pre-stapled to the front of the seat, finishing the attachment on the sides and back of the backrest.

Aplique las tachas de hierro (K) sobre el TNT negro, ya previamente grapado en la parte frontal del asiento, finalizando la fijación en los laterales y trasero del respaldo.

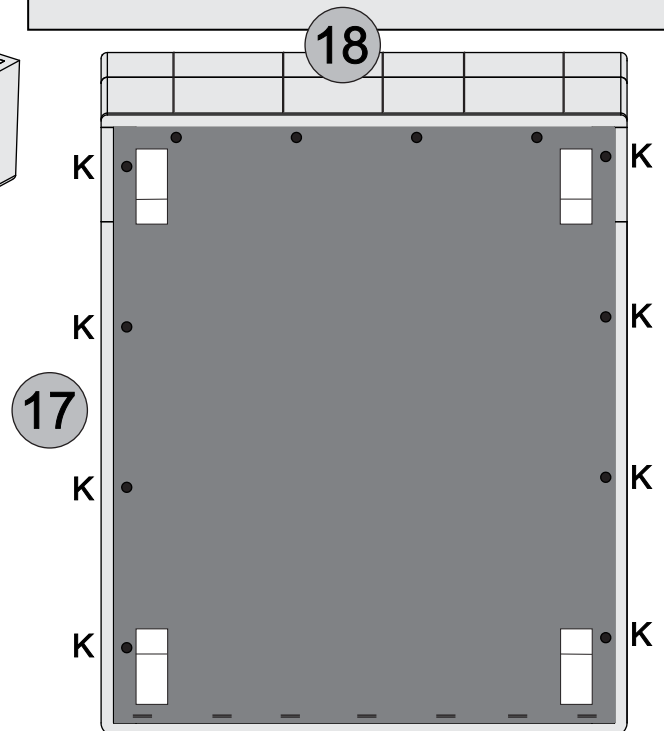

8°

N  
3x  
J  
1x



Aplique a cola nas furações do espaldar e nas cavilhas, antes de encaixá-las.

Apply the glue to the holes in the back and studs before attaching them.

Aplique la cola en los agujeros del respaldo y en los pernos, antes de encajarlos.

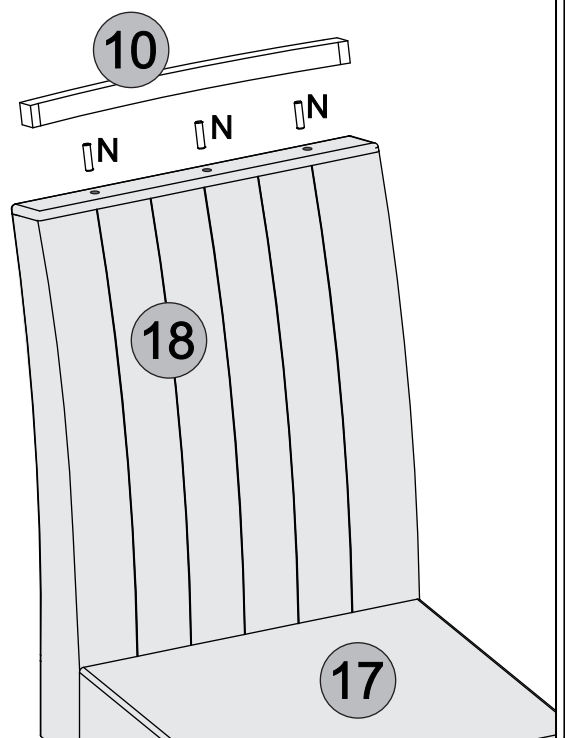
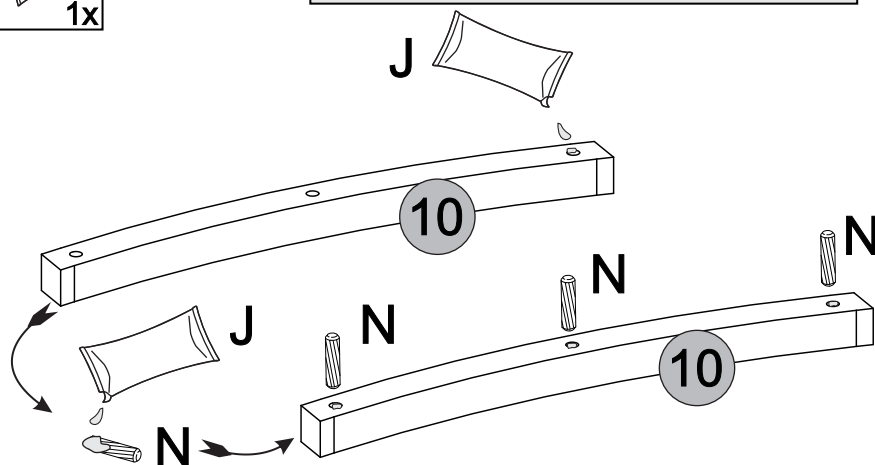

## Aspecto Final:

Final View: | Vista Final





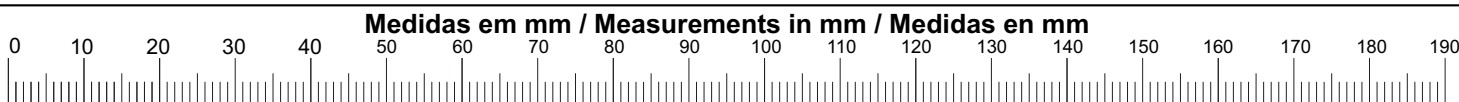
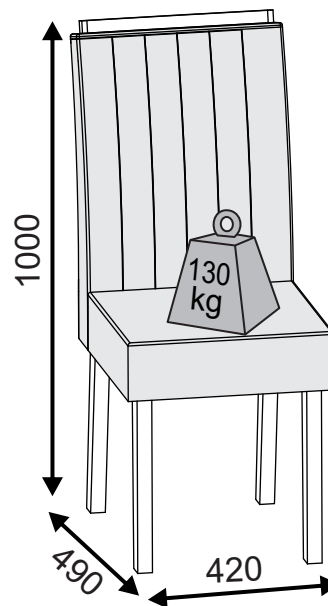



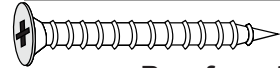

### Carga Suportável Weight supported | Peso soportado

Peso máximo de carga ilustrado no desenho acima distribuídos de maneira uniforme.  
Maximum load weight illustrated in the drawing above distributed from uniform way.  
Peso máximo de carga ilustrado en el dibujo arriba distribuidos de manera uniforme.

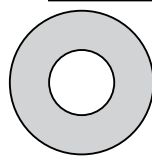

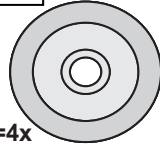
## Acessórios/Accessories/Accesorios

Para montar uma cadeira / To mount a chair  
Para montar una silla

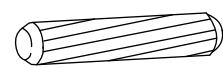
<b>A</b> <b>cód. assistência 10319</b> Support code   Cód. asistencia  5,0x35mm Screw Tornillo 5,0x35mm <b>Parafuso 5,0 x 35mm = 16x</b>	<b>B</b> <b>cód. assistência 8945</b> Support code   Cód. asistencia  <b>Barra Roscada 90mm x 1/4 = 2x</b> 90mm x 1/4 Threaded rod Barra Roscada 90mm x 1/4	
<b>C</b> <b>cód. assistência 8463</b> Support code   Cód. asistencia  30x8,5mm Half moon nut Tuerca media luna 30x8,5mm <b>Porca Meia-Lua 30 x 8.5mm = 2x</b>	<b>D</b> <b>cód. assistência 8461</b> Support code   Cód. asistencia  1/4 " Cylindrical Nut Tuerca Cilíndrica 1/4 " <b>Porca Cilíndrica 1/4" = 2x</b>	<b>E</b> <b>cód. assistência 18547</b> Support code   Cód. asistencia  1/4x3/4 Flat washer Arandela lisa 1/4x3/4 <b>Arruela Lisa 1/4x3/4 = 8x</b>
<b>F</b> <b>cód. assistência 18548</b> Support code   Cód. asistencia  1/4"x40mm Screw Tornillo 1/4"x40mm <b>Parafuso 1/4"x40mm = 8x</b>	<b>G</b> <b>cód. assistência 9212</b> Support code   Cód. asistencia  Wrench Llave de boca <b>Chave de boca = 1x</b>	<b>H</b> <b>cód. assistência 5536</b> Support code   Cód. asistencia  20mm Sliding shoe Zapato deslizante 20mm <b>Sapata Deslizadora 20mm=4x</b>
<b>I</b> <b>cód. assistência 10320</b> Support code   Cód. asistencia  3,0x12mm Screw Tornillo 3,0x12mm <b>Parafuso 3,0 x 12mm = 4x</b>	<b>J</b> <b>cód. assistência 18549</b> Support code   Cód. asistencia  Glue Pegamento Sache de Cola = 1x <i>Tempo de secagem da cola 24 horas após a utilização. Drying time of the glue 24 hours after use. Tiempo de secado del pegamento 24 horas después de su uso.</i>	<b>K</b> <b>cód. assistência 18550</b> Support code   Cód. asistencia  8x16 iron tack tacha de hierro 8x16 <b>Tacha de ferro 8x16 = 12x</b>
<b>L</b> <b>cód. assistência 11962 - Rústico Malbec/Demolição</b> Support code   Cód. asistencia 16218 - Carvalho Americano 16519 - R.Terrara <b>Giz de Correção= 1x</b> Correction chalk   Tiza de corrección <i>*Utilizar o giz de correção para pequenas imperfeições na pintura. Use the correction chalk for minor imperfections in the painting. Utilizar la tiza de corrección para pequeñas imperfecciones en la pintura.</i>	<b>M</b> <b>cód. assistência 8460</b> Support code   Cód. asistencia  1/4 x 7/16 Hexagonal Nut Tuerca Hexagonal 1/4 x 7/16 <b>Porca sextavada 1/4x7/16 = 2x</b>	<b>N</b> <b>cód. assistência 18546</b> Support code   Cód. asistencia  Dowel 8x40mm Pin 8x40mm <b>Cavilha 8x40mm</b>

Atualizado em: Up-to-date on Modernization en

18/02/2019 **CDIP-009-18.434**  
Revisão - 01

**Ao solicitar assistência, informe o número da peça e código do acessório**

When requesting assistance, tell the part number and serial number of accessory

Al solicitar asistencia, informe el número de pieza y número de serie del accesorio

