

# 18.980 - BASE RAVENA

## Vista Explodida: detalle de las piezas parts detail

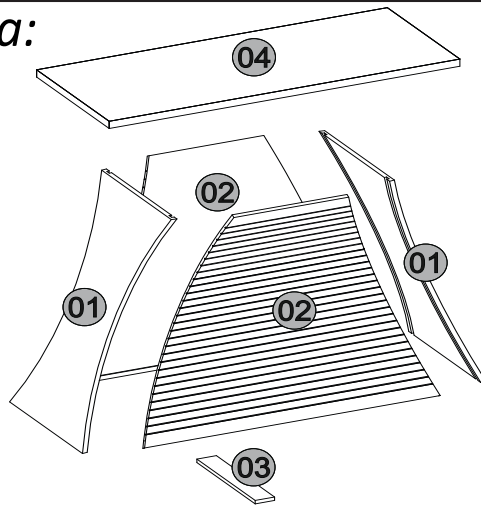

### ENTENDENDO OS CÓDIGOS:

ENTENDIENDO LOS CÓDIGOS CARIBE EN LAS PIEZAS:  
UNDERSTANDING THE CODES STAMPED IN THE PARTS:

0000.0000

**LEGENDA DE CORES:**  
COLOR SUBTITLE:  
LEYENDA DE COLORES:

cód. da cor  
color number  
número de color

cód. da peça  
piece number  
número de pieza

000 - CRU  
047 - RÚSTICO MALBEC  
060 - RÚSTICO TERRARA  
055 - OFF WHITE  
054 - DEMOLIÇÃO

ENTENDENDO OS CÓDIGOS CARIMBADO NAS PEÇAS:  
ENTENDIENDO LOS CÓDIGOS CARIBE EN LAS PIEZAS:  
UNDERSTANDING THE CODES STAMPED IN THE PARTS:

00000|000|00

Número da peça  
Piece number  
Número de pieza

Número do lote  
lot number  
número de lote

Código do produto  
Product number  
Número de producto

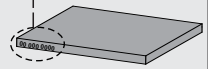

### Instruções para a montagem do produto:



**Separe as peças e acessórios de maneira organizada.**  
Separate the parts and accessories in an organized way.  
Separe las piezas y accesorios de forma organizada



**Forrar o chão com o papelão das embalagens.**  
Cover the floor with the cardboard from the pack.  
Cubra el suelo con el papelón de los embalajes.



**É necessário uma pessoa para montar o produto.**  
It's necessary one person to assembly the product.  
Se requiere una persona para montar el producto.

**Ferramentas necessárias**(não fornecidas)  
**Herramientas necesarias** (no suministradas)  
**Required tools** (not provided)



### Cuidados para conservação e limpeza do móvel:



**Não molhar o móvel e não expor em lugar úmido.**  
Do not moisten the furniture and not to expose in moist places.  
No moje el mueble y no ponga en local humedo.



**Não expor o móvel próximo de fontes de calor.**  
Do not expose furniture next to heat sources.  
No exponga el mueble cerca de fuentes emitan calor.



**Não usar produtos abrasivos.**  
Do not use abrasive products.  
No utilice productos abrasivos.



**Limpe com flanela limpa e seca.**  
For cleaning use a clean and dry cloth.  
Limpe con franela limpia e seca.

Nº	PEÇAS	PIECES	PIEZAS	CÓDIGO PEÇAS	RÚSTICO TERRARA	OFF WHITE/DEMOLIÇÃO	RÚSTICO MALBEC	MEDIDAS (mm) MEASURES (mm) MEDIDAS (mm)	Qt.
01	Lateral	Side	Lateral	19011	60	054	47	805x450x15	02
02	Frontal	Front	Frente	19012	60	055	47	912x780x12	02
03	Trava	Locks	Bloquear	19013	00	00	00	345x60x12	01
04	Apoio do tampo	Table top support	Apoyo de la tapa	19014	00	00	00	1083x448x25	01

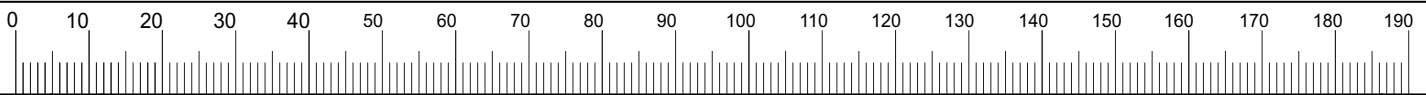

Cod. Assist.Téc.	Cod.	Acessórios / Accessories / Accesorios			Qty.
16984	A	Cantoneira 17,5X17,5X44mm	Metal bracket 17,5X17,5X44mm	Suporte de metal 17,5X17,5X44mm	12
8440	B	Cantoneira metálica 18x18mm	Metal bracket 18x18mm	Suporte de metal 18x18mm	02
1049	C	Parafuso 5,0x50 cabeça chata estrutural	Structural flat head screw 5,0x50	Tornillo 5,0x50 cabeça plana estrutural	04
18486	D	Parafuso 4,0x35 cabeça chata	Screw 4,0x35 flathead	Tornillo 4,0x35 cabeça plana	18
1043	E	Parafuso 4,0x12 cabeça flangeada	Screw 4,0x12 flanged head	Tornillo 4,0x12 cabeça embridada	52
8443	F	Sapata deslizadora 15x6mm preta	Sliding shoe 15x6mm	Zapata Deslizadora 15x6	04
1068	G	Prego 10x10 com cabeça	Nail 10x10 with head	Clavo 10x10	04
18549	H	Sache de Cola	Sachet of cola	Saché de cola	02

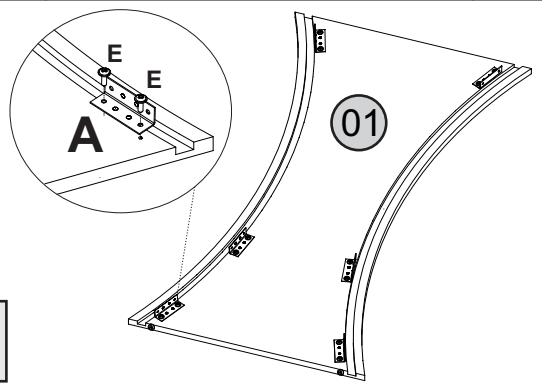
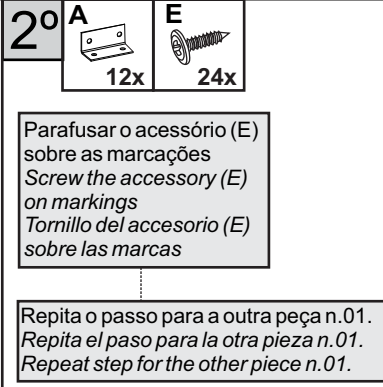
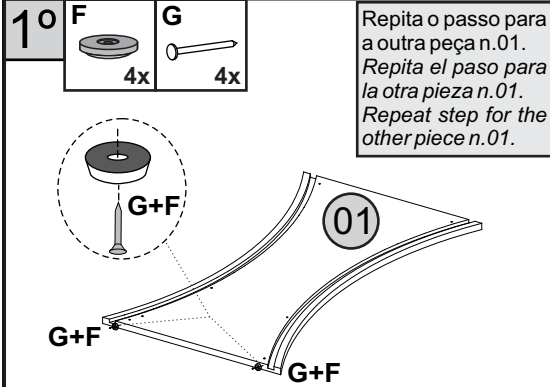



Atualizado em: Up-to-date on  
Modernization en  
12/04/2019 CDIP-009-18980  
Revisão - 01

**Ao solicitar assistência, informe o número da peça e código do acessório**  
When requesting assistance, tell the part number and serial number of accessory  
Al solicitar asistencia, informe el número de pieza y número de serie del accesorio



# 18.980 - BASE RAVENA

**3º**  **E** 24x  **H** 02x

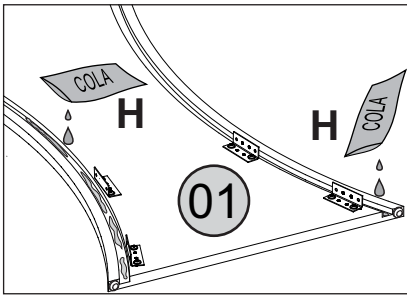

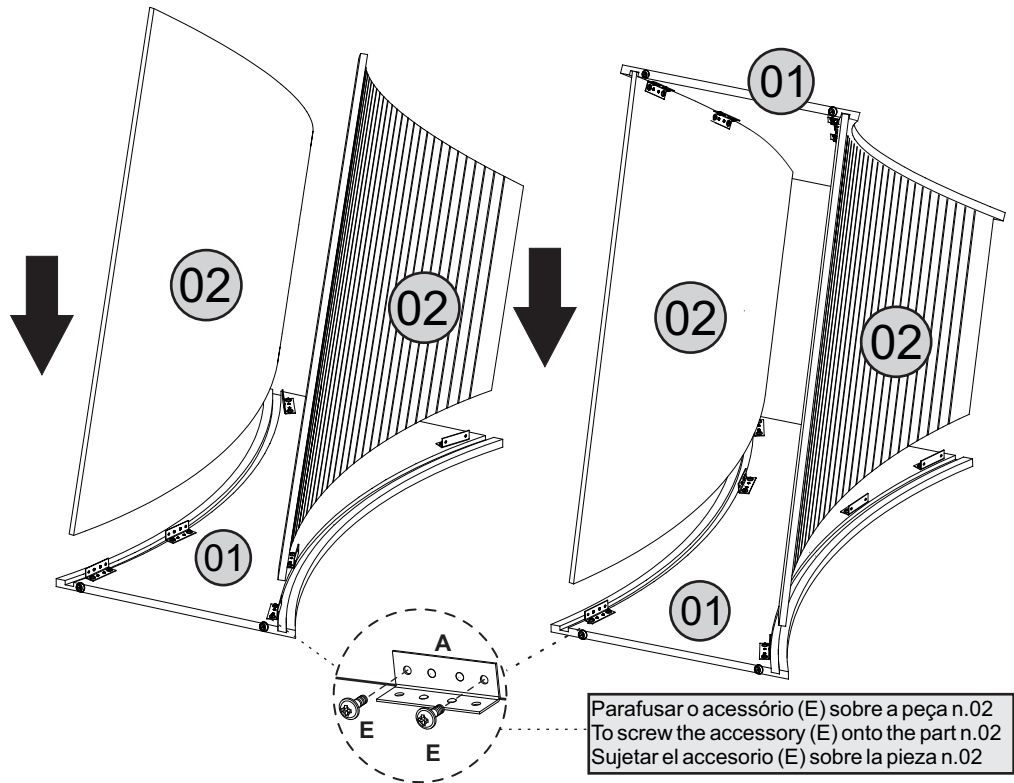

**ATENÇÃO/CAUTION/ATENCIÓN**  
**1º** Aplicar cola (H) na parte interna do canal da peça 01  
 Apply glue (H) to the inside of the channel of part 01  
 Aplicar adhesivo (H) en la parte interna del canal de la pieza 01

**2º**-Encaixar a peça n.02, seguindo o canal da peça n.01.  
 Insert part n.02, following the channel of part n.01.  
 Enganche la pieza n.02, siguiendo el canal de la pieza n.01



Parafusar o acessório (E) sobre a peça n.02  
 To screw the accessory (E) onto the part n.02  
 Sujetar el accesorio (E) sobre la pieza n.02

**4º**  **E** 4x  **B** 2x

**1º** - Posicionar a peça n.03 com 20mm de afastamento do final da peça n.02

Position part n.03 with 20 mm clearance from the end of the piece n.02

Posicionar la pieza n.03 con 20mm de alejamiento del final de la pieza n.02

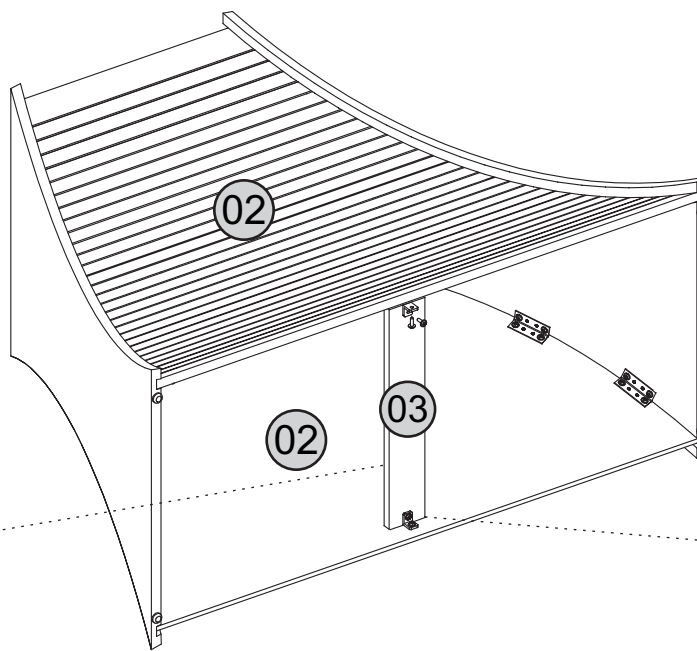
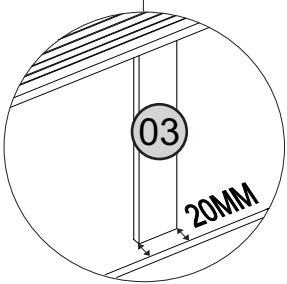

**2º** - Utilizar o acessório (B) e (E) para fixar na peça n.02 e n.03  
 Use accessory (B) and (E) to attach to part n.02 and n.03  
 Utilizar el accesorio (B) y (E) para fijar en la pieza n.02 y n.03

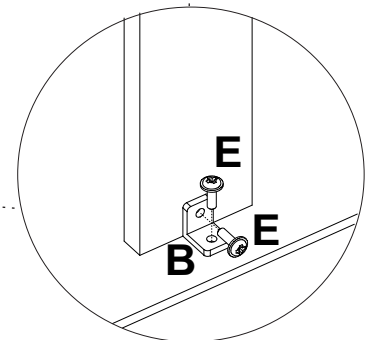

**5º**  **C** 4x

Posicione a **peça nº04** de forma que a furação coincida com a furação da peça nº 01, para só assim fixar o parafuso.  
 Position **part nº04** so that the drilling matches the nº 01, in order to fix the screw.

Coloque la **pieza nº04** de forma que el taladro coincida con la perforación de la pieza nº01, para sólo fijar el tornillo.

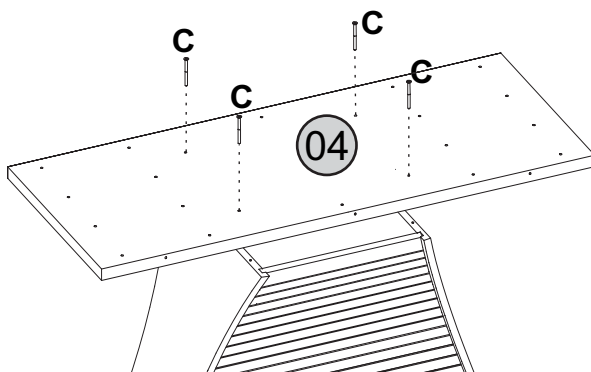

**6º** **Aspecto Final**  
**Vista Final**  
**Final View**

