

**CÓDIGO DE PEÇAS | CODE OF PIECES | CÓDIGO DE PIEZAS**

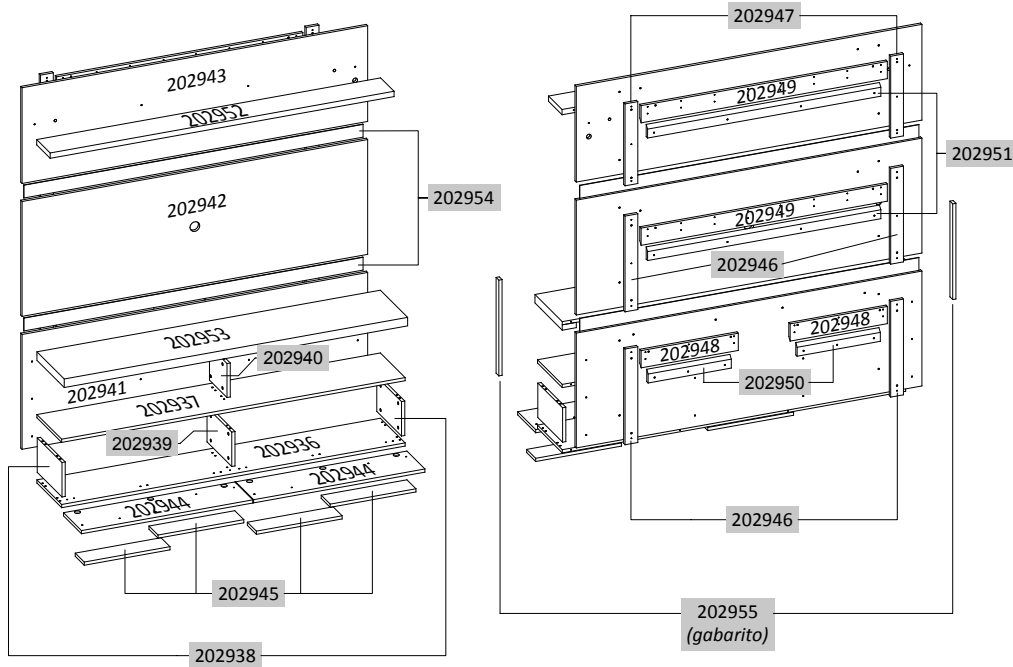

**INSTRUÇÕES**

- Prepare a montagem do móvel próximo ao local que ele ficará definitivamente e evite deslocá-lo depois de montado;  
- Forre o chão com papelão ou similar e utilize a isomanta que vem entre as peças para evitar o contato entre elas durante a montagem;  
- Monte o móvel obedecendo a ordem numérica da **seqüência de montagem (S.M.)**, identificando as peças pelo **código de peça (C.P.)** carimbado na mesma, de acordo com a tabela.

**INSTRUCTIONS**

- Prepare the assembly of the close piece of furniture to the place that it will be definitively and avoid to move after done. Will be definitively and avoid to move after done;  
- Cover the ground with cardboard or similar and use the isomanta that it comes among the pieces to avoid the contact among them during the assembly;  
- Set up the piece of furniture obeying the numeric order of the **assembly sequence (S.M.)**, identifying the pieces by **code of piece (C.P.)** stamped in the same, in agreement with the table.

**INSTRUCCIONES**

- Prepare la montaje del mobiliario proximo al lugar que estará definitivamente y evite mover después de hecho;  
- Tape la suelo con cartón o similar y use la "isomanta" que viene entre las piezas para evitar el contacto entre ellos durante la montaje;  
- Monte el mobiliario obedeciendo el orden numérico de la **sucesión de montaje (S.M.)**, identificando las piezas por el **código de piezas (C.P.)** de la misma estampado en esta, de acuerdo con la tabla.

**ASPECTO FINAL | FINAL ASPECT**

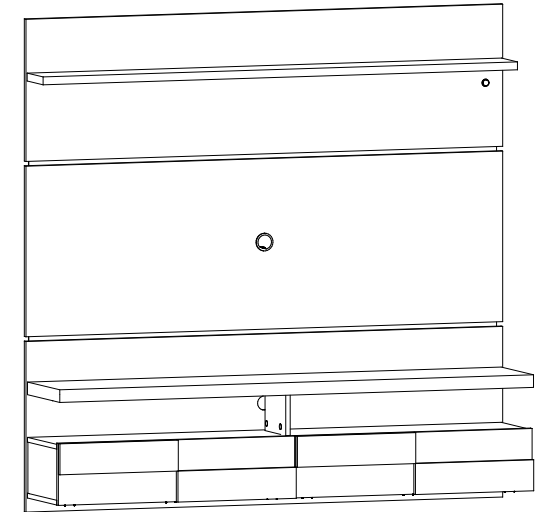

\*Dimensões em metros | *Dimensions in meters* | *Dimensiones en metros*

Espaço para Tv: → 1,600 m ↑ 0,950 m  
Dimensão do Produto: → 1,600 m ↑ 1,560 m ↯ 0,330 m

REF.:	PEÇAS PIECE PIEZA	MATÉRIA PRIMA	DIMENSÕES* DIMENSIONS DIMENSIONES	QUANT.
202936	Base   Base   Base	MDP	1,590 x 0,270 x 0,015	1
202937	Tampo DVD   DVD top   Tampo DVD	MDP	1,590 x 0,270 x 0,015	1
202938	Lateral esquerda/direita   Left/right side   Lateral izquierda/derecha	MDP	0,270 x 0,162 x 0,015	2
202939	Divisão   Division   División	MDP	0,270 x 0,162 x 0,015	1
202940	Divisão DVD   DVD Division   División DVD	MDP	0,191 x 0,160 x 0,015	1
202941	Painel inferior   Bottom panel   Panel inferior	MDP	1,600 x 0,540 x 0,015	1
202942	Painel central   Central panel   Panel central	MDP	1,600 x 0,540 x 0,015	1
202943	Painel superior   Superior panel   Panel superior	MDP	1,600 x 0,450 x 0,015	1
202944	Porta   Door   Puerta	MDP	0,793 x 0,196 x 0,015	2
202945	Complemento da porta   Door Complement   Complemento de la puerta	MDP	0,397 x 0,098 x 0,015	4
202946	Travessa lateral maior   Largest side crossbar   Travesa lateral mayor	MDP	0,450 x 0,059 x 0,015	4
202947	Travessa lateral menor   Minor side guard   Travesaño lateral menor	MDP	0,385 x 0,059 x 0,015	2
202948	Apoio do painel menor   Small panel support   Apoyo panel pequeño	MDP	0,450 x 0,081 x 0,015	2
202949	Apoio do painel maior   Largest panel support   Apoyo panel mayor	MDP	1,140 x 0,081 x 0,015	2
202950	Apoio da parede menor   Lower wall support   Apoyo pared más pequeño	MDP	0,385 x 0,058 x 0,015	2
202951	Apoio da parede maior   Larger wall support   Soporte del pared	MDP	1,080 x 0,058 x 0,015	2
202952	Prateleira superior   Top shelf   Estanteria superior	MDP	1,592 x 0,147 x 0,025	1
202953	Tampo   Top   Table top	MDP	1,590 x 0,298 x 0,040	1
202954	Fundo complemento   Bottom background   Fondo complementario	MDF	1,570 x 0,060 x 0,003	2
202955	Gabarito para fixar cunha   Fixing wedge jig   Plantilla para fijar cuña	MDP	0,448 x 0,030 x 0,015	2

**ACESSÓRIOS | ACCESSORIES | ACESORIOS**

**1º PASSO | PASS | PASO**

PEÇAS  
PIECES  
PIEZAS

S.M.	C.P.
01	202936
02	202938
03	202939
04	202938
05	202937

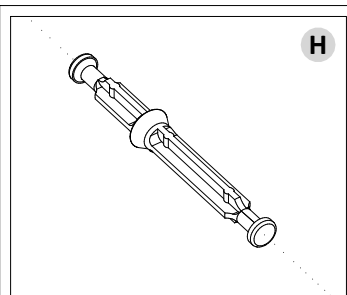
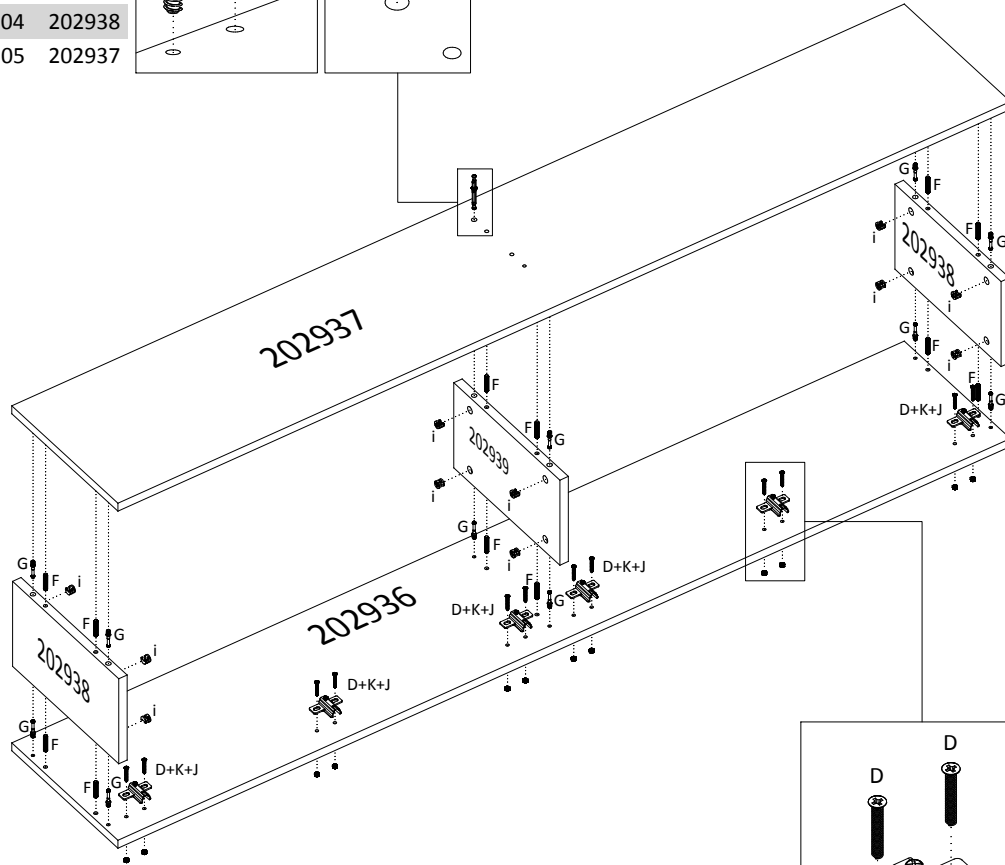
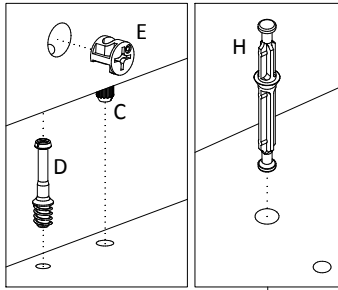

H

LADO SUPERIOR  
UPPER SIDE  
PARTE SUPERIOR

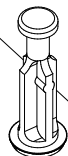

LADO INFERIOR  
BOTTOM SIDE  
LADO INFERIOR

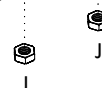
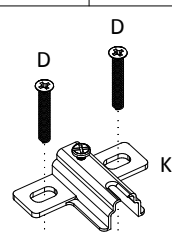
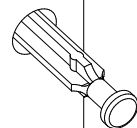

**2º PASSO | PASS | PASO**

Obs.: passar COLA [Q] nas peças 202948 antes de fixa-las no painel.

PEÇAS  
PIECES  
PIEZAS

S.M.	C.P.
01	202941
02	202948
03	202948
04	202946
05	202946
06	202954

**Quebrar as sobras das cavilhas [F] conforme imagem.**  
Break the leftover of the bolts [F] according to the image.  
Romper las sobras de los tornillos [F] conforme imagen.

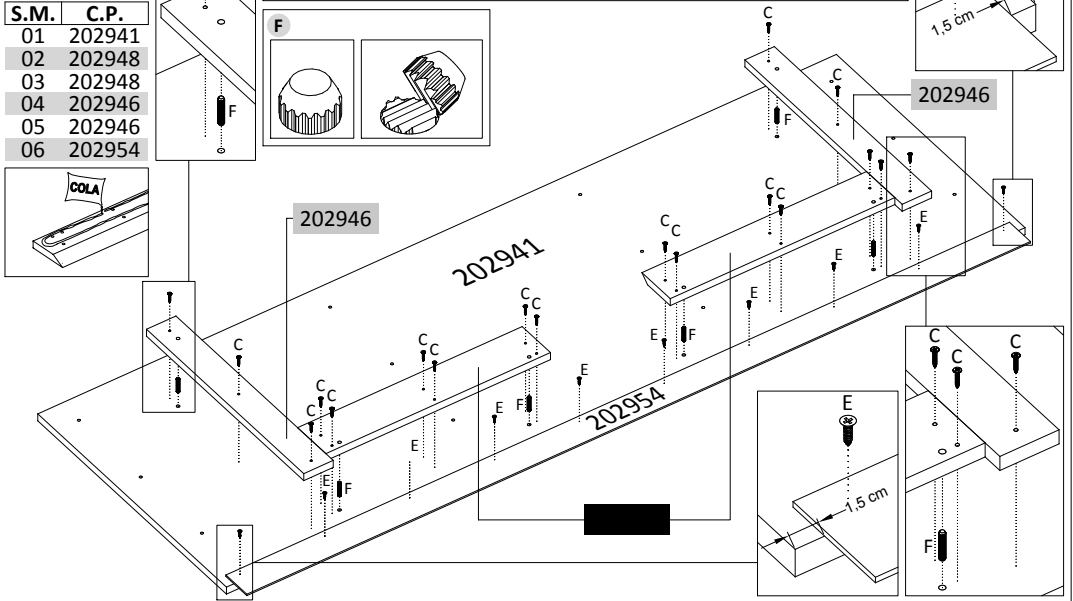
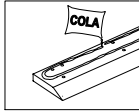
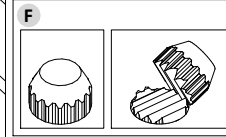

**3º PASSO | PASS | PASO**

PEÇAS  
PIECES  
PIEZAS

S.M.	C.P.
01	202940
02	202953

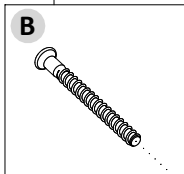
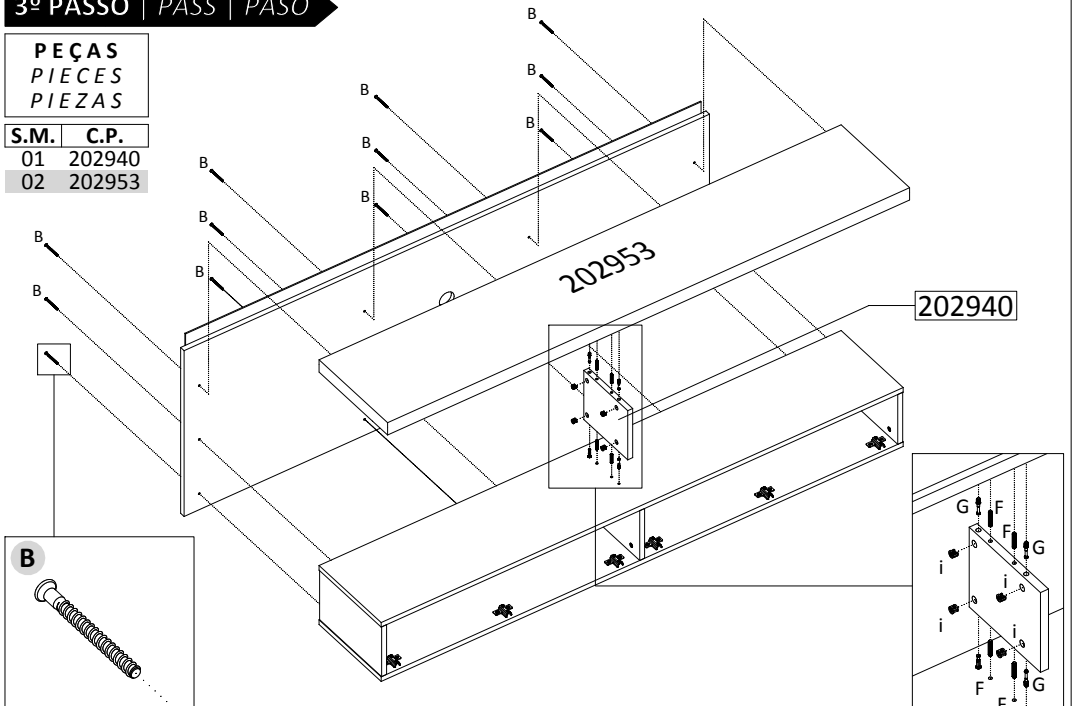

B

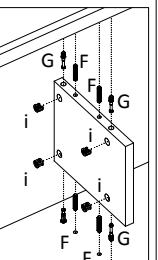

**4º PASSO | PASS | PASO**

Obs.: passar COLA [Q] nas peças 202948 antes de fixá-las no painel.

PEÇAS  
PIECES  
PIEZAS

**Quebrar as sobras das cavilhas [F] conforme imagem.**  
Break the leftover of the bolts [F] according to the image.  
Romper las sobras de los tornillos [F] conforme imagen.

S.M.	C.P.
01	202942
02	202948
03	202948
04	202946
05	202946
06	202946

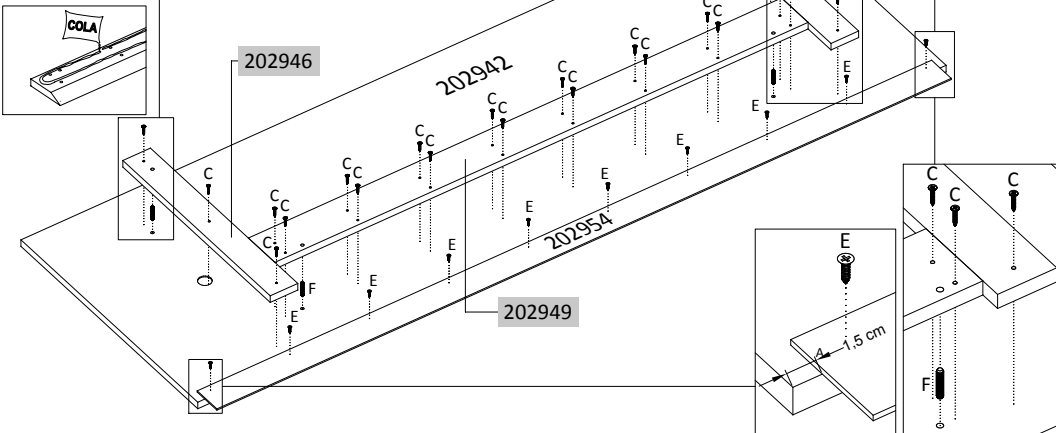
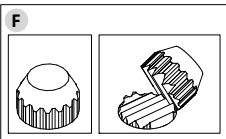

**5º PASSO | PASS | PASO**

Obs.: passar COLA [Q] na peça 202949 antes de fixá-la no painel.

PEÇAS  
PIECES  
PIEZAS

S.M.	C.P.
01	202943
02	202949
03	202947
04	202947
05	202991

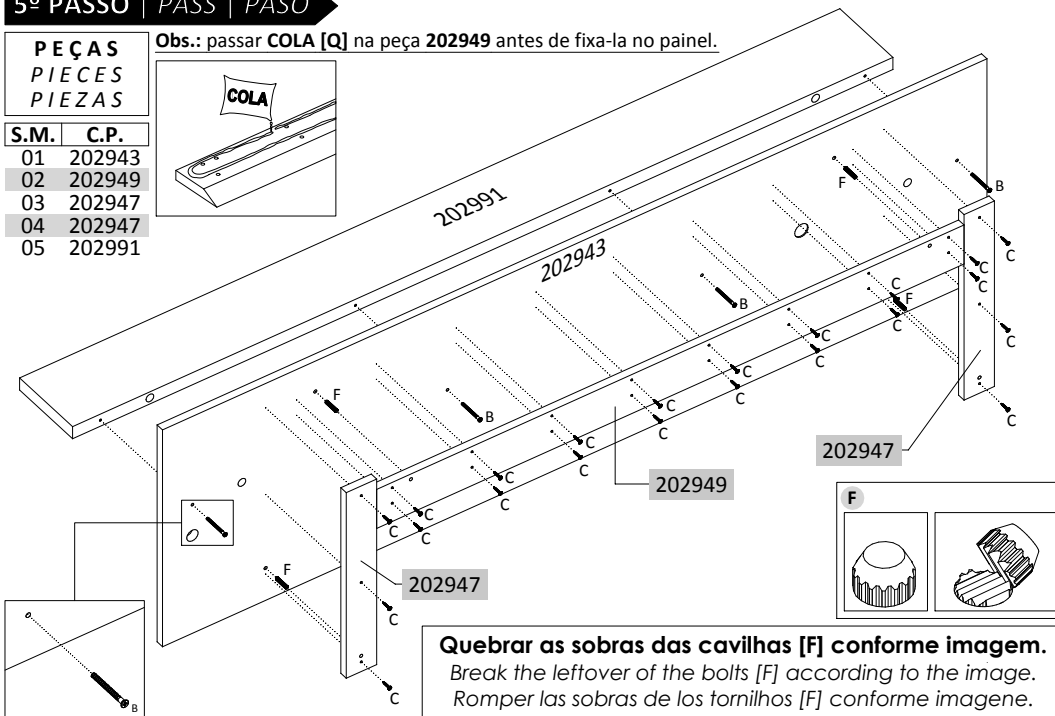
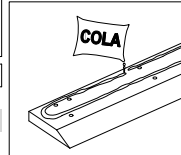

**Quebrar as sobras das cavilhas [F] conforme imagem.**  
Break the leftover of the bolts [F] according to the image.  
Romper las sobras de los tornillos [F] conforme imagen.

**6º PASSO | PASS | PASO**

PEÇAS  
PIECES  
PIEZAS

S.M.	C.P.
01	202950
02	202950
03	202951

ALTURA RECOMENDADA  
RECOMMENDED HEIGHT  
ALTURA RECOMENDADA

Parede | Wall | Pared

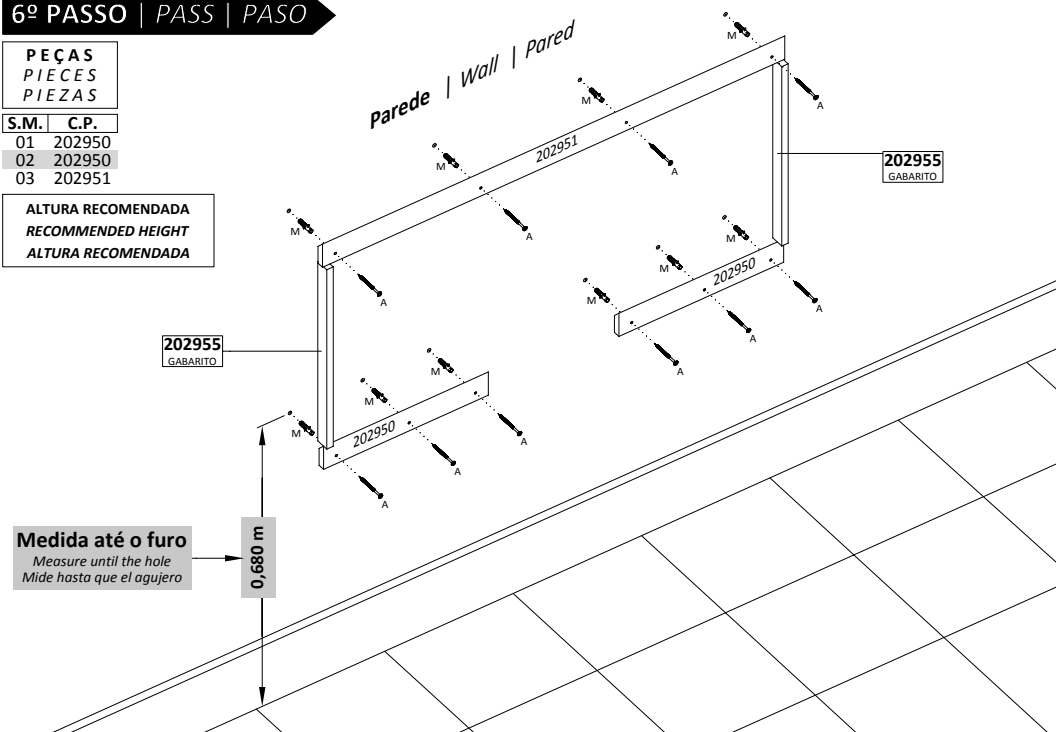

Medida até o furo  
Measure until the hole  
Mide hasta que el agujero

0,680 m

**7º PASSO | PASS | PASO**

Parede | Wall | Pared

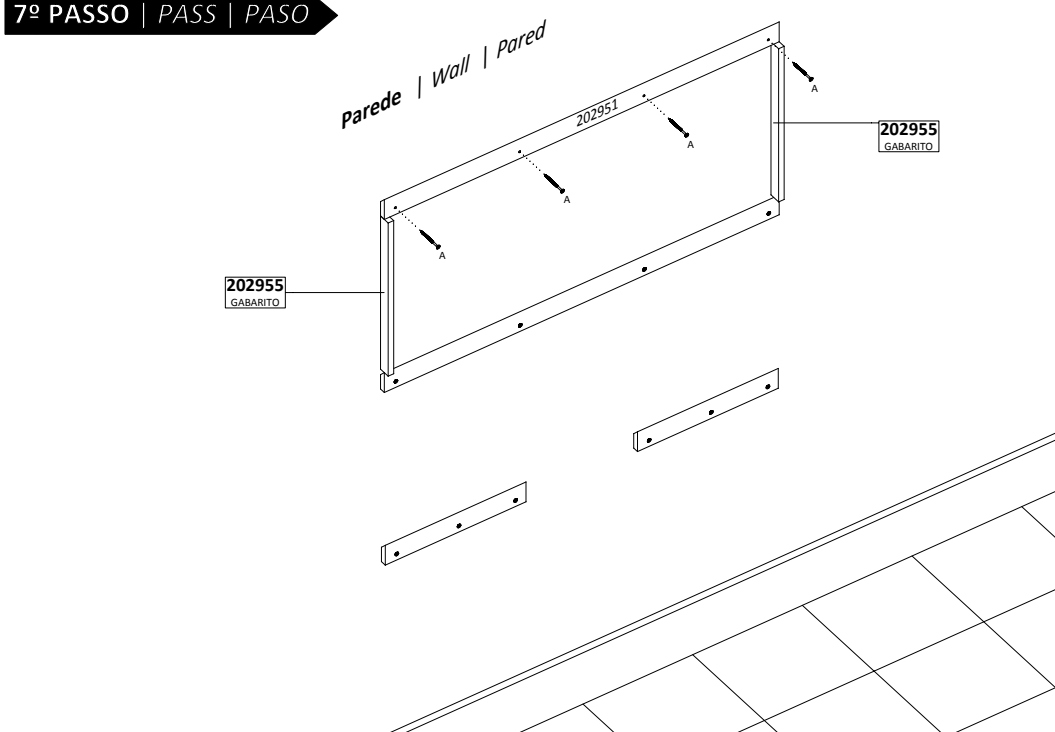

8º PASSO | PASS | PASO

PEÇAS  
PIECES  
PIEZAS

S.M.	C.P.
01	202944
02	202945
03	202945
04	202944
05	202945
06	202945

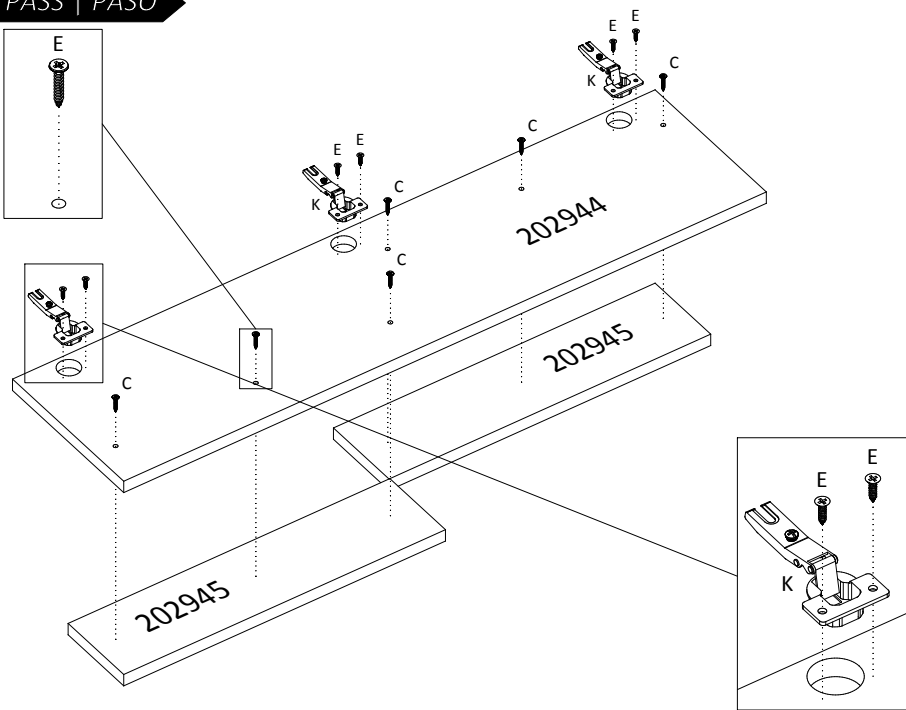

9º PASSO | PASS | PASO

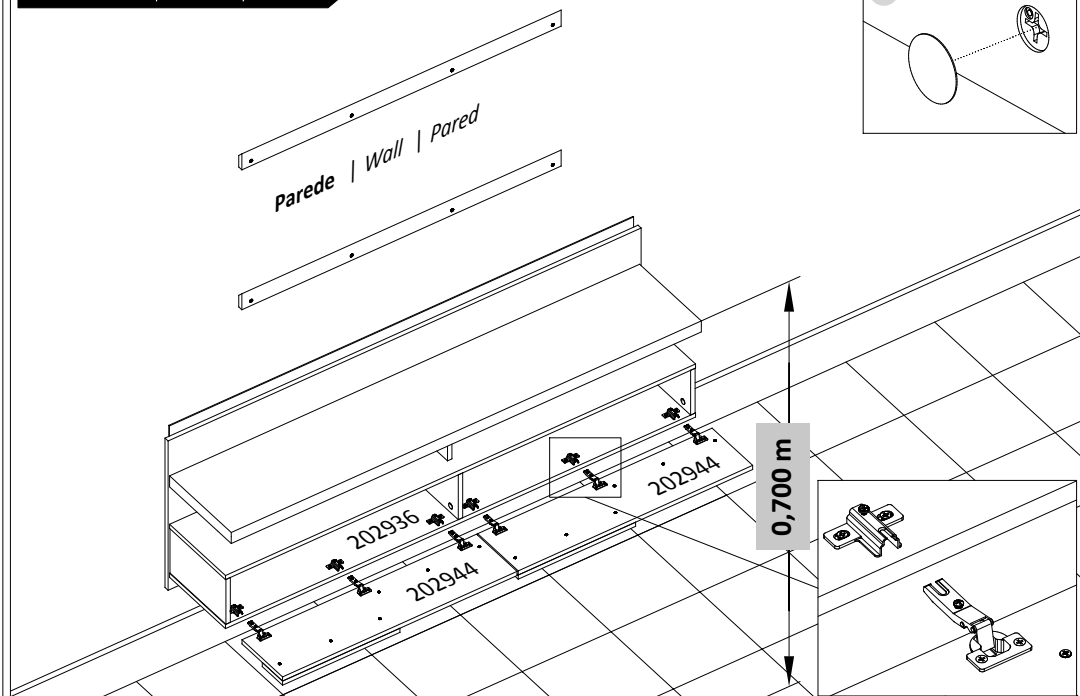

10º PASSO | PASS | PASO

parede | Wall | Pared

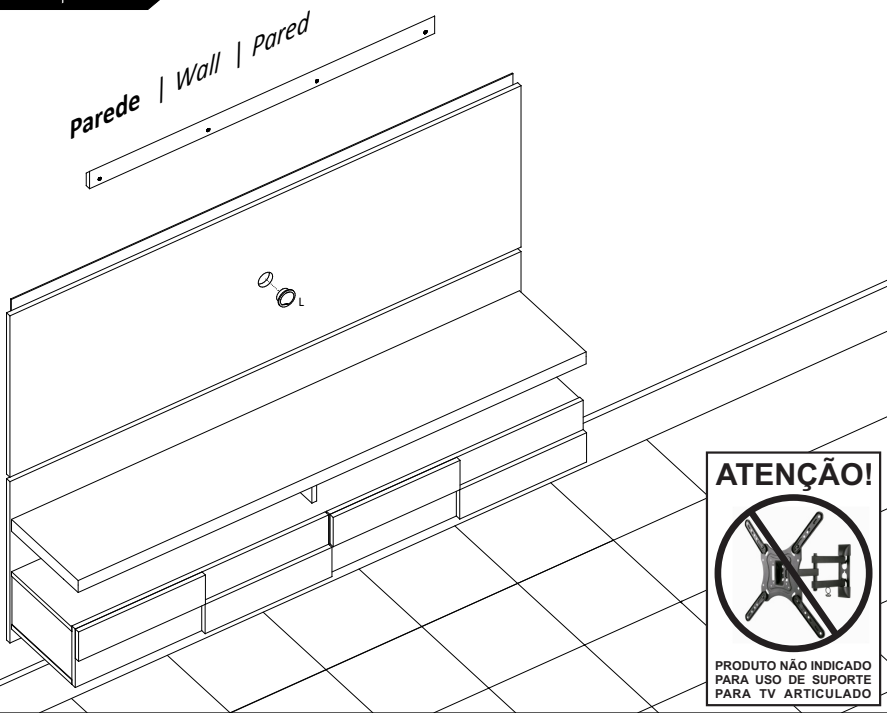

**ATENÇÃO!**



PRODUTO NÃO INDICADO  
PARA USO DE SUPORTE  
PARÁ TV ARTICULADO

11º PASSO | PASS | PASO

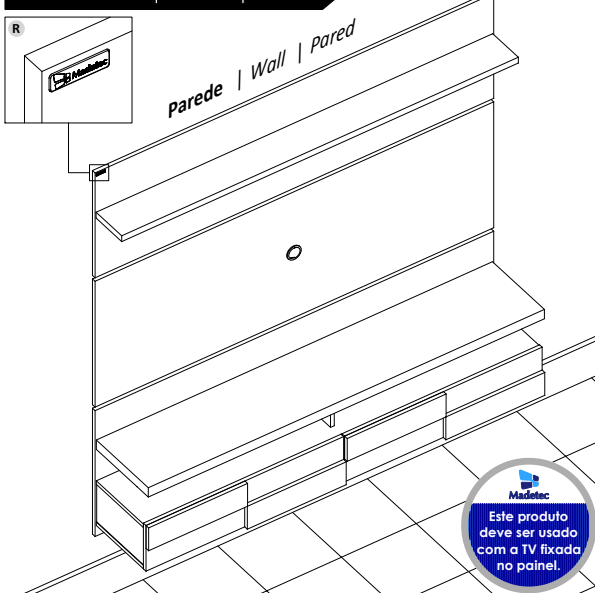

Comece a instalação da luminária encaixando o interruptor no furo do painel e depois passe o fio pelo segundo furo.

Start the installation of the luminaire fitting the switch in the top hole and then pass the string through the second hole.

Comienza la instalación del montaje de interruptor en el orificio superior de la luminaria y luego pasar la cadena a través del segundo agujero.

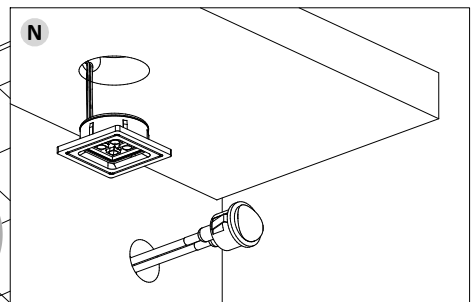

CUIDADOS ESPECIAIS | SPECIAL CARES | CUIDADOS ESPECIALES:

LIMPEZA: Pano limpo umedecido em água e sabão neutro - BRILHO: Flanela seca  
CLEANING: Clean cloth humidified in water and neutral soap - SHINE: Dry flannel  
LIMPIEZA: Tela limpia humedecida en la agua y el jabón neutro - BRILLO: Franela seca