

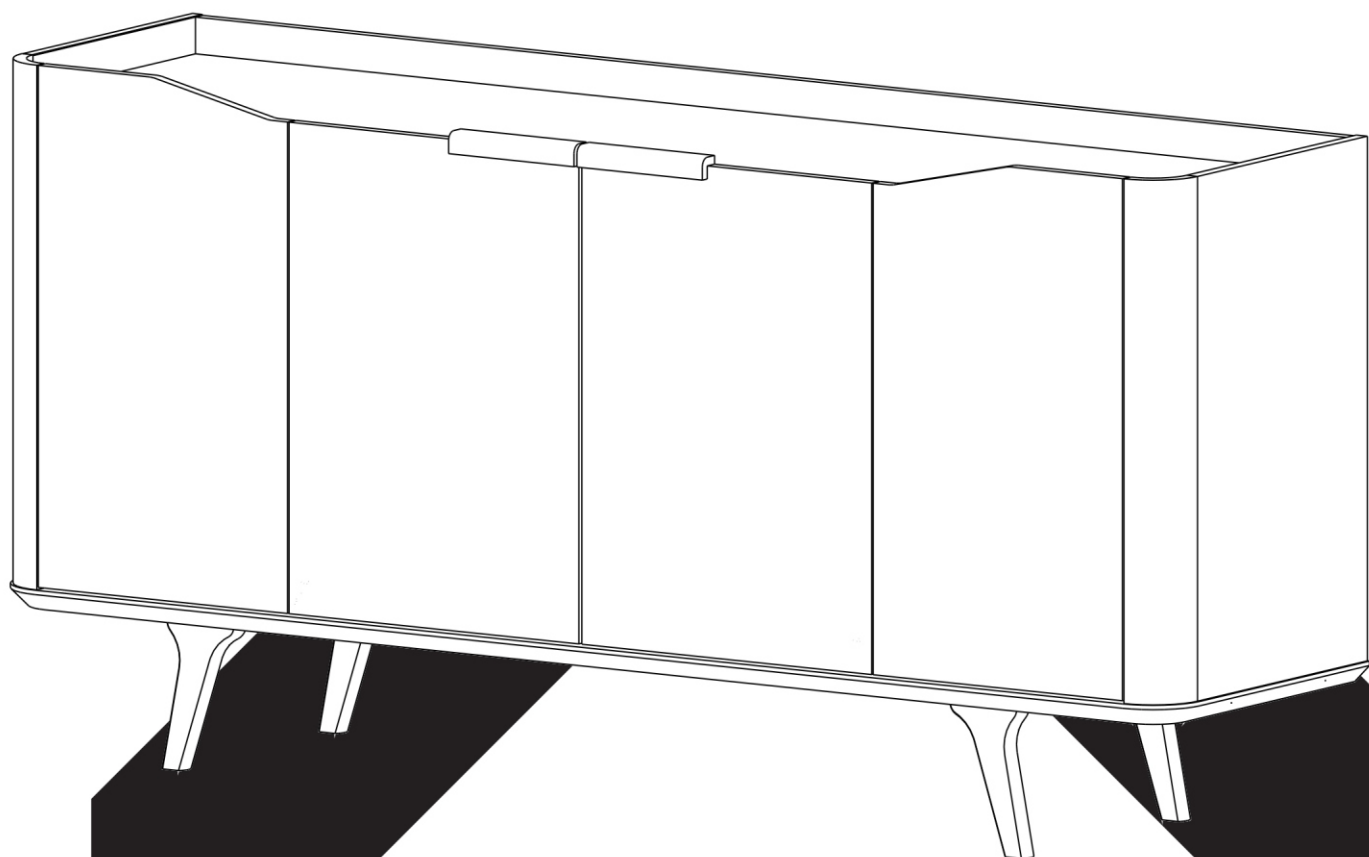









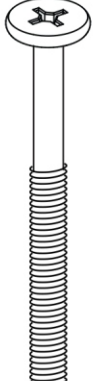
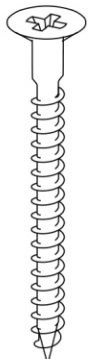
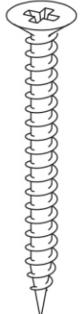
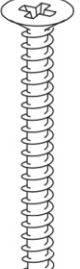

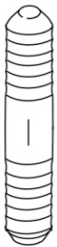
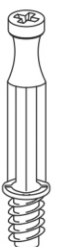
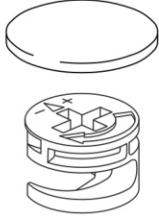
IMKOL

Buffet Arc 4P

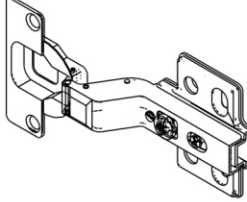
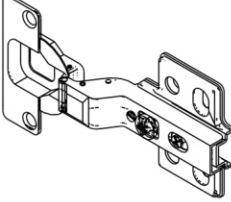

ACESSÓRIOS

ACCESORIOS - ACCESSORIES

A	B	C	D	E	F	G	H	I	J
									
PARAFUSO MQ 6x62	PARAFUSO SOB. CH 5x45	PARAFUSO CH 4x40	PARAFUSO CH 5x35	PARAFUSO CH 3x14	CAVILHA PLÁSTICA 6x30	PARAFUSO XFIX AÇO	CASTANHA XFIX 15mm TAPA FURO 19mm	BUCHA MINIFIX	PORCA CILÍNDRICA 20x10x1/4
04 x	08 x	02 x	04 x	68 x	38 x	22 x	22 x	06 x	04 x
K	L	M	N	O	P	Q	R	S	
									
TRAPÉZIO	SAPATA BOTÃO	TAPA FURO ADESIVO 13mm	PREGO 8X8	DOBRADIÇA SLOW SUPER ALTA 35mm	DOBRADIÇA SLOW ALTA 35mm	SUPORTE P/ FUNDO	CANTONEIRA 2 FUROS	TAPA FURO 8mm	
02 x	04 x	08 x	20 x	04 x	04 x	12 x	02 x	04 x	

VISTA GERAL

VISIÓN DE CONJUNTO - GLOBAL VIEW

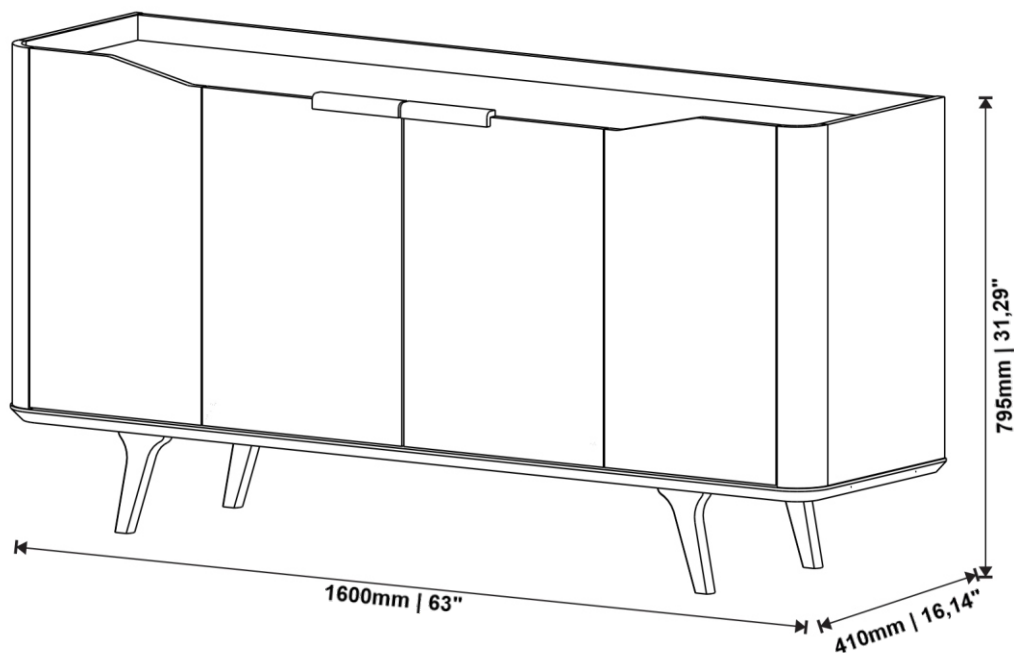

CONSERVANDO O SEU MÓVEL / MANTENIENDO SU MOBILIARIO / MAINTAINING YOUR FURNITURE

LIMPEZA DO MÓVEL / LIMPIANDO SU MOBILIARIO / CLEANING

Na remoção da poeira utilizar flanela limpa e levemente umedecida, em seguida flanela seca para remoção da umidade. Para limpar el polvo utiliza una flanela limpia y humedecida y después una flanela seca para quitar la humedad. To remove dust use a clean flannel slightly moistened and afterwards a dry flannel to remove the humidity.

RECOMENDAÇÕES DE USO / RECOMENDACIONES DE USO / USE RECOMMENDATIONS

Não expor a luz solar e locais úmidos. No exponga a la luz solar y lugares húmedos. Do not expose to sun light and humid places.

Não encostar o móvel na parede para evitar transmissão de umidade. No apoye el mobiliario en la pared evitar la transmisión de humedad. Do not lean the furniture in the wall to avoid humidity transmission.

Não movimentar o móvel com os rodízios travados. No mueva su mobiliario con las ruedas cerradas. Do not move your furniture with the wheels locked.

Este produto tem 6 meses de garantia contra defeito de fabricação. Este producto tiene garantía de 6 meses contra defecto de fabricación. This product has 6 months warranty against production defect.

PORTUGUÊS	ESPAÑOL	ENGLISH	DIM. (mm)
01- Pé Direito	01- Pie Derecho	01- Right Foot	01- 170 x 95 x 25
02- Pé Esquerdo	02- Pie Izquierdo	02- Left Foot	02- 170 x 95 x 25
03- Base	03- Base	03- Base	03- 1600 x 410 x 25
04- Curva Esquerda	04- Curva Izquierda	04- Left Curve	04- 600 x 95 x 15
05- Batente da Porta	05- Tope de Puerta	05- Door Stop	05- 542 x 100 x 15
06- Lateral Externa Esquerda	06- Lado Externo Izquierdo	06- Left External Side	06- 600 x 347 x 15
07- Prateleira Externa	07- Repisa Externa	07- External Shelf	07- 378 x 340 x 15
08- Lateral Interna	08- Lado Interno	08- Internal Side	08- 542 x 377 x 15
09- Prateleira Central	09- Repisa Central	09- Central Shelf	09- 778 x 370 x 15
10- Curva Direita	10- Curva Derecha	10- Right Curve	10- 600 x 95 x 15
11- Lateral Externa Direita	11- Lado Externo Derecho	11- Right External Side	11- 600 x 347 x 15
12- Tampo	12- Tapa	12- Top	12- 1564 x 392 x 15
13- Régua Moldura	13- Regla de Marco	13- Frame Ruler	13- 1564 x 38 x 15
14- Porta Externa Esquerda	14- Puerta Externa Izquierda	14- External Left Door	14- 597 x 337 x 15
15- Porta Interna Esquerda	15- Puerta Interna Izquierda	15- Internal Left Door	15- 562 x 395 x 15
16- Porta Interna Direita	16- Puerta Interna Derecha	16- Internal Right Door	16- 562 x 395 x 15
17- Porta Externa Direita	17- Puerta Externa Derecha	17- External Right Door	17- 597 x 337 x 15
18- Puxador	18- Manija	18- Handle	18- 170 x 25 x 25
F1- Fundo Traseiro	F1- Fondo Trasero	F1- Rear Bottom	19- 1574 x 276 x 3

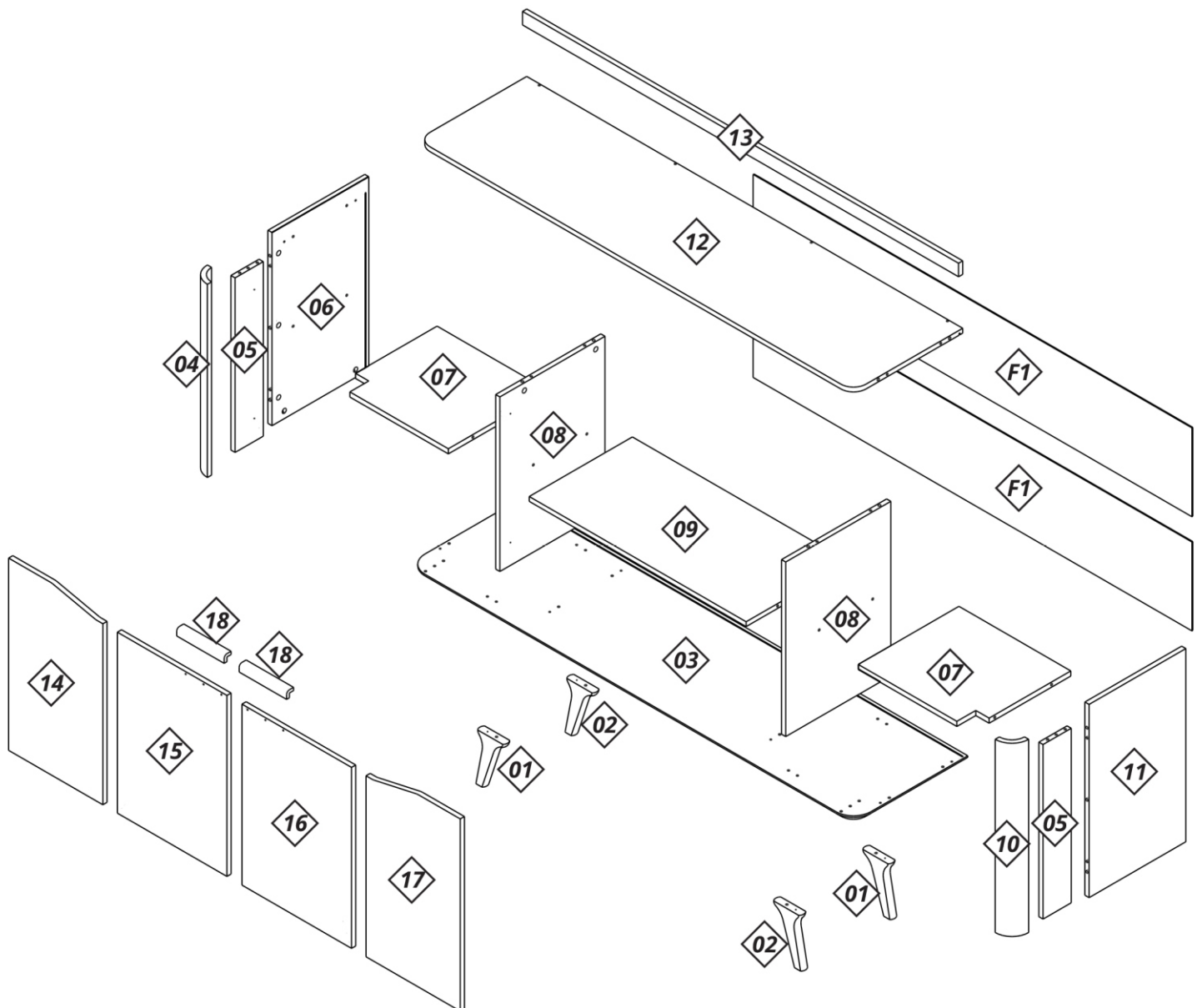

PRÉ-MONTAGEM

PRÉ-MONTAJE - PRE ASSEMBLY

IMPORTANTE

IMPORTANTE - IMPORTANT

A MONTAGEM DEVE SER REALIZADA POR UM PROFISSIONAL DE MONTAGEM.

EL MONTAJE DEBE SER HECHO POR UN MONTADOR DE MUEBLES.

ASSEMBLY MUST BE CARRIED OUT BY AN ASSEMBLY PROFESSIONAL.

1

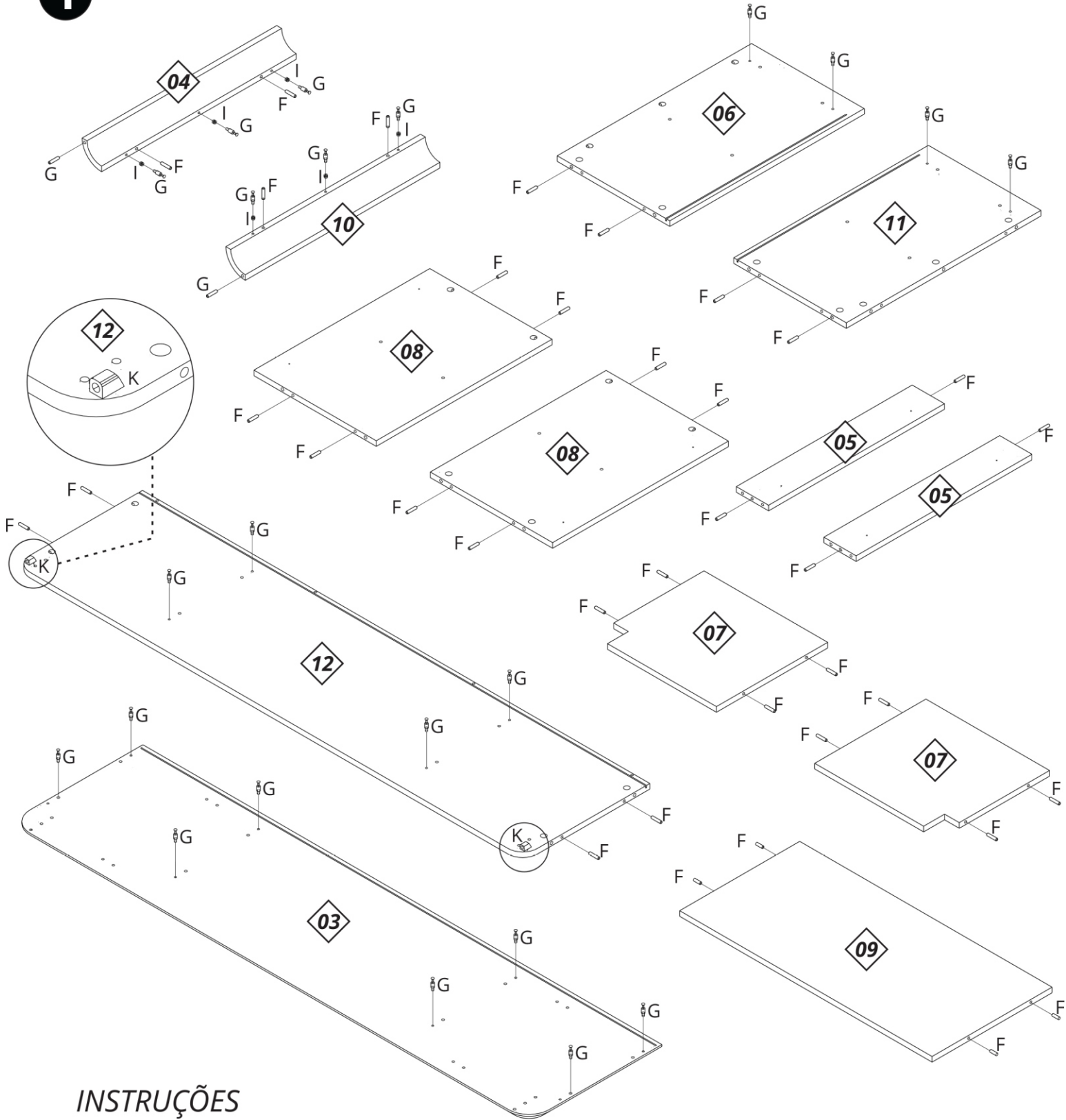

INSTRUÇÕES

INSTRUCCIONES - INSTRUCTIONS

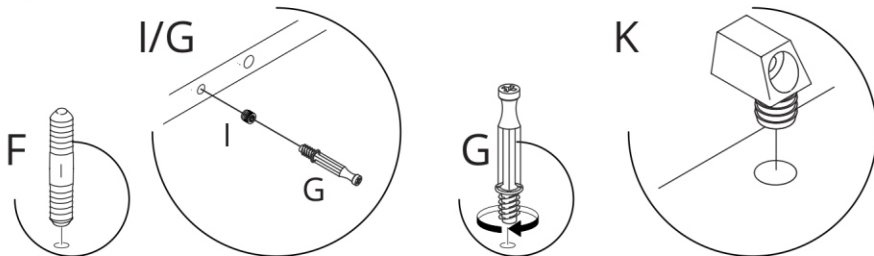

MONTAGEM

MONTAJE - ASSEMBLY

VIRAR O PRODUTO COM O TAMPO (12) VOLTADO AO CHÃO,
UTILIZE A EMBALAGEM PARA FERRAR O PISO E EVITAR DANOS À PINTURA.
VOLVER EL PRODUCTO CON LA PARTE SUPERIOR (12) DE VUELTA AL SUELO,
UTILICE EL PAQUETE PARA CUBRIR EL SUELO Y EVITE DAÑOS A LA PINTURA.
TURN THE PRODUCT WITH THE TOP (12) BACK TO THE FLOOR,
USE THE PACKAGE TO COVER THE FLOOR AND AVOID DAMAGE TO THE FINISHING.

1

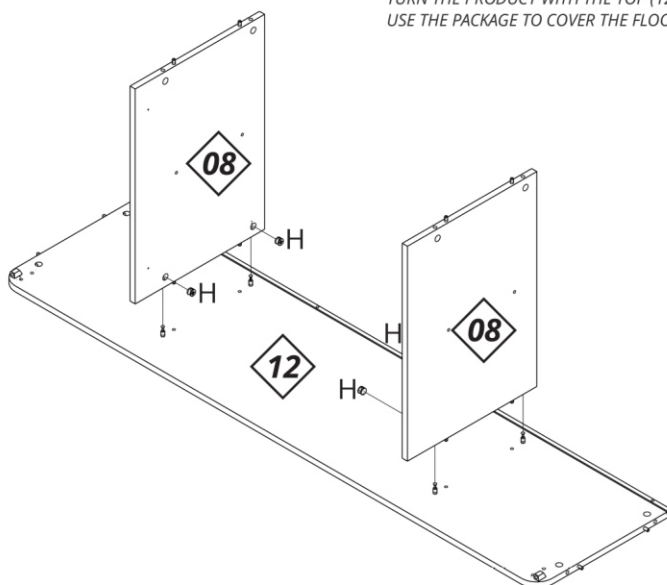

2

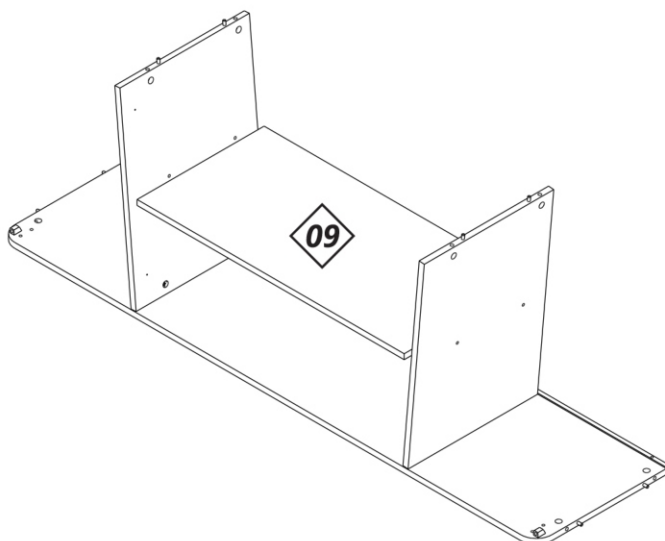

3

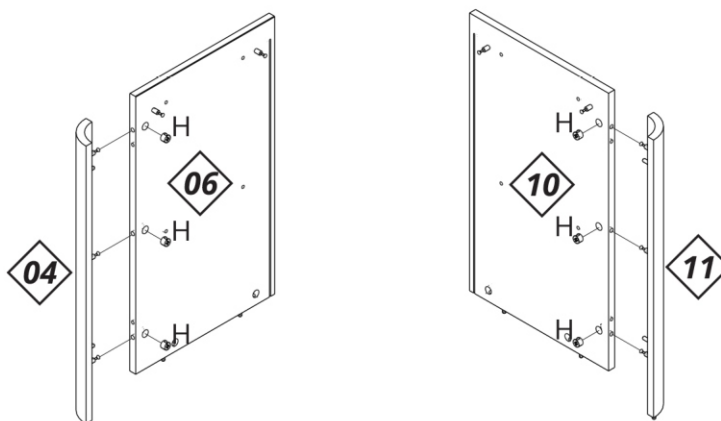

INSTRUÇÕES

INSTRUCCIONES - INSTRUCTIONS

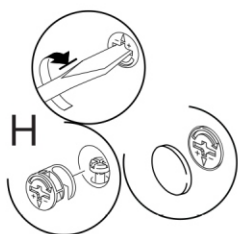

MONTAGEM

MONTAJE - ASSEMBLY

4

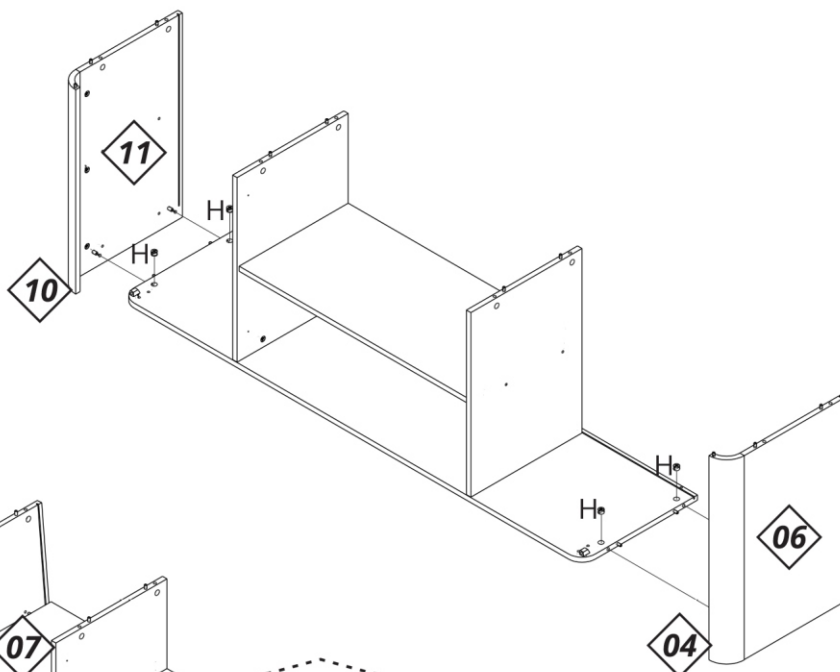

5

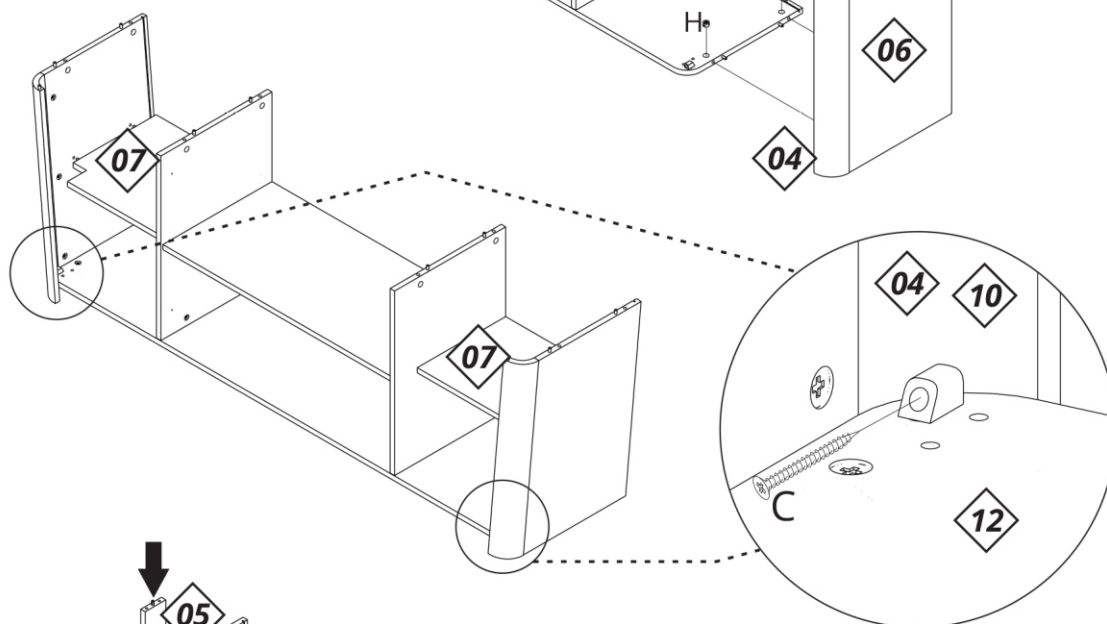

6

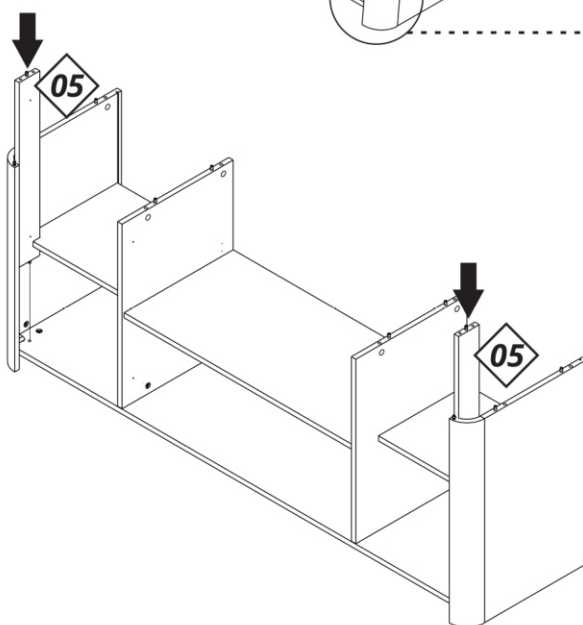

INSTRUÇÕES

INSTRUCCIONES - INSTRUCTIONS

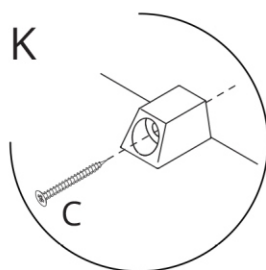
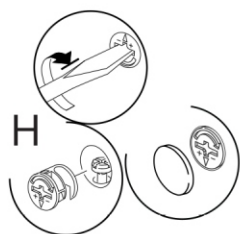

MONTAGEM

MONTAJE - ASSEMBLY

7

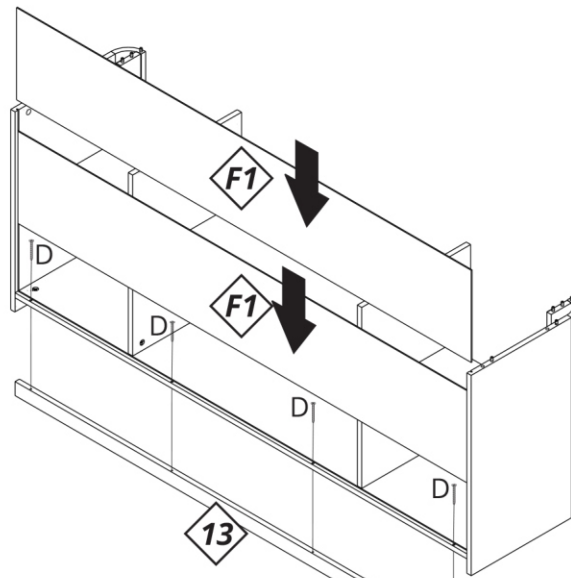

8

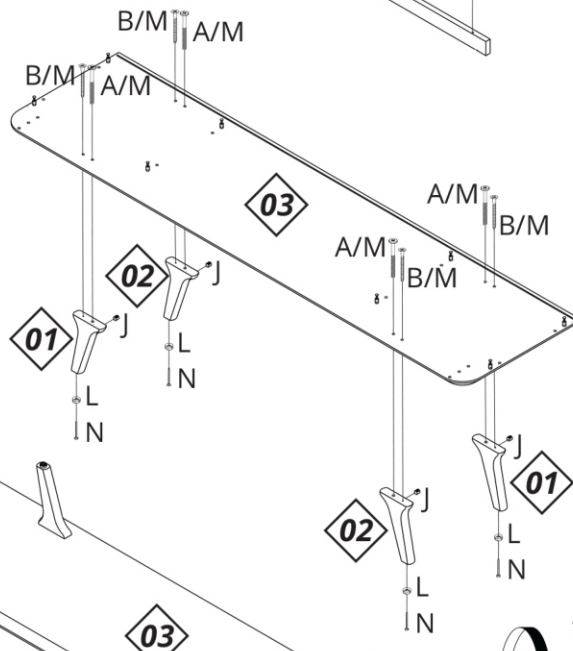

9

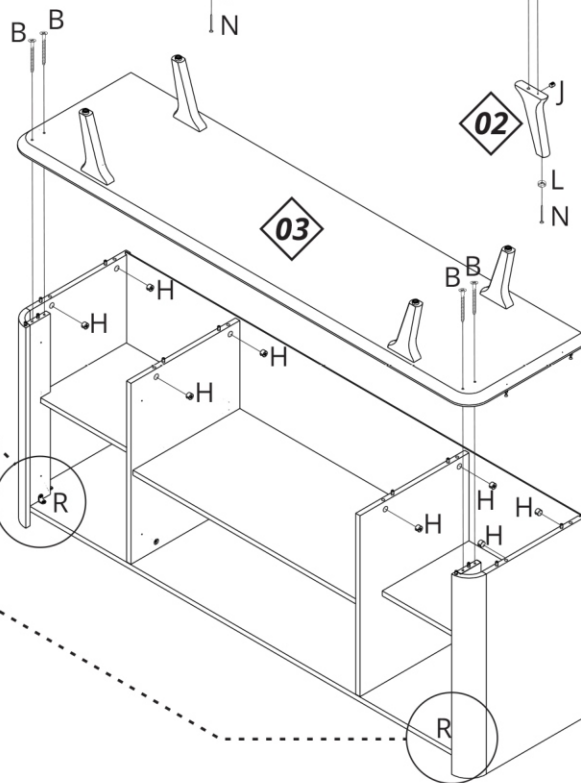

APÓS A MONTAGEM DO PASSO "8",
ROTACIONAR O CONJUNTO PARA
CONTINUAR O PROCESSO.
DESPUÉS DE LA ASAMBLEA DEL PASO "8",
GIRAR EL CONJUNTO PARA CONTINUAR EL PROCESO.
AFTER THE ASSEMBLY OF THE STEP "8",
ROTATE THE SET TO CONTINUE THE PROCESS.

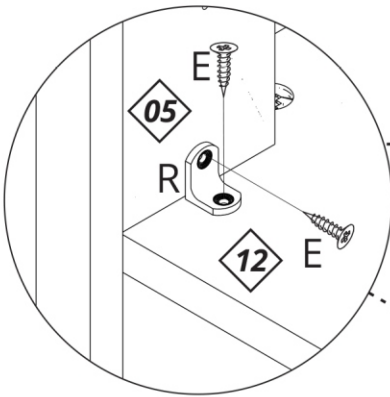

INSTRUÇÕES

INSTRUCCIONES - INSTRUCTIONS

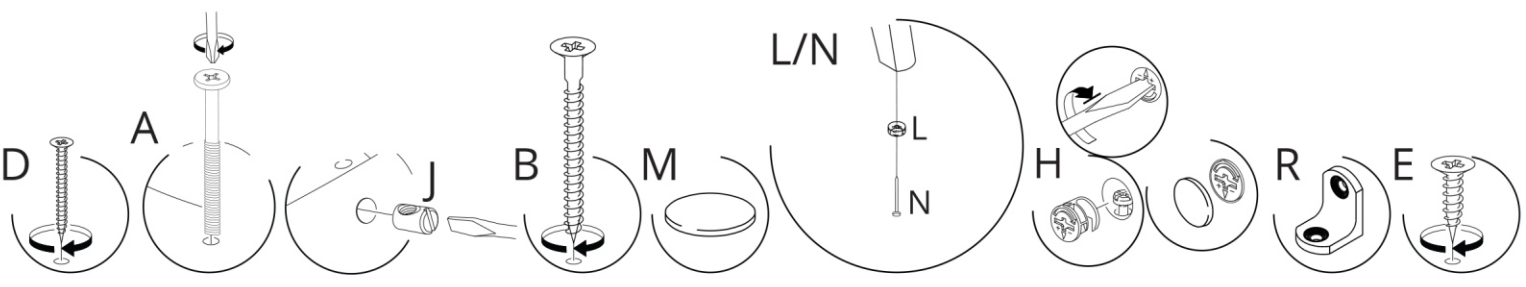

MONTAGEM

MONTAJE - ASSEMBLY

10

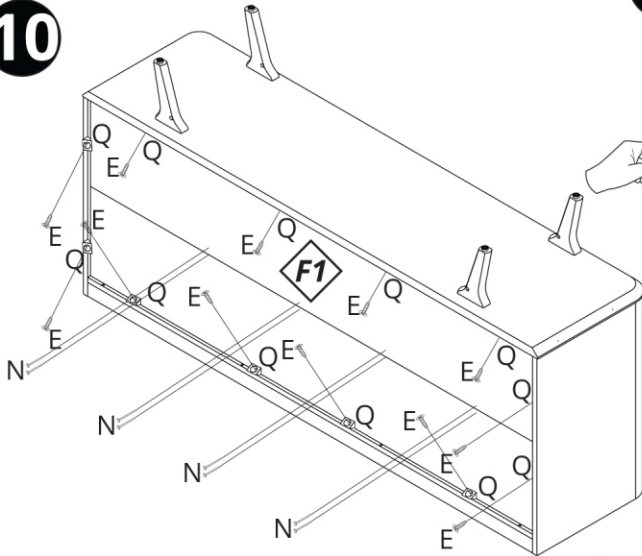

11

A MONTAGEM DOS PUXADORES NAS PORTAS CENTRAIS É OPCIONAL.
EL MONTAJE DE LAS MANIJAS EN LAS PUERTAS CENTRALES ES OPCIONAL.
THE HANDLES ASSEMBLY IN CENTRAL DOORS IS OPTIONAL.

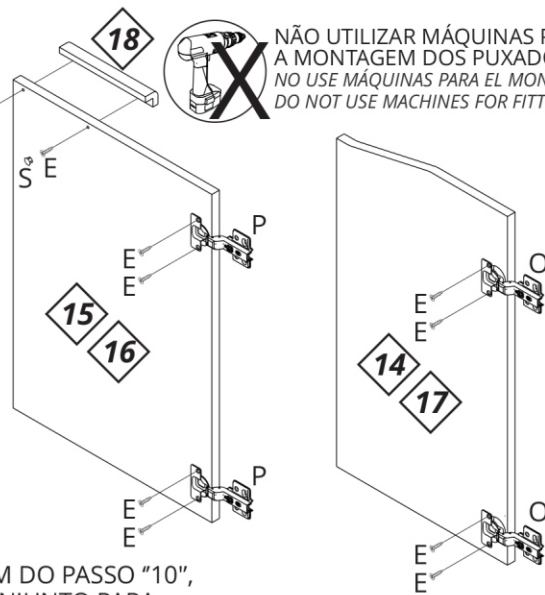

NÃO UTILIZAR MÁQUINAS PARA A MONTAGEM DOS PUXADORES.
NO USE MÁQUINAS PARA EL MONTAJE DE LAS MANIJAS.
DO NOT USE MACHINES FOR FITTING THE HANDLES.

12

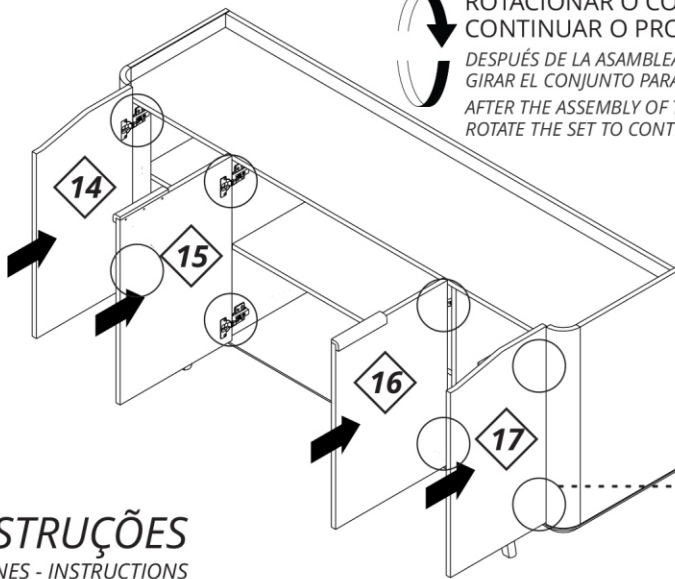

APÓS A MONTAGEM DO PASSO "10",
ROTACIONAR O CONJUNTO PARA
CONTINUAR O PROCESSO.

DESPUÉS DE LA ASAMBLEA DEL PASO "10",
GIRAR EL CONJUNTO PARA CONTINUAR EL PROCESO.
AFTER THE ASSEMBLY OF THE STEP "10",
ROTATE THE SET TO CONTINUE THE PROCESS.

INSTRUÇÕES

INSTRUCCIONES - INSTRUCTIONS

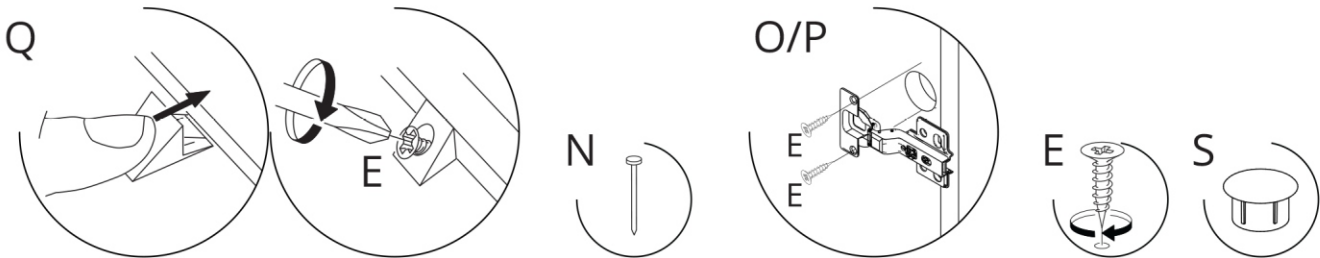

CAPACIDADE DE CARGA

CAPACIDAD DE CARGA - LOAD CAPACITY

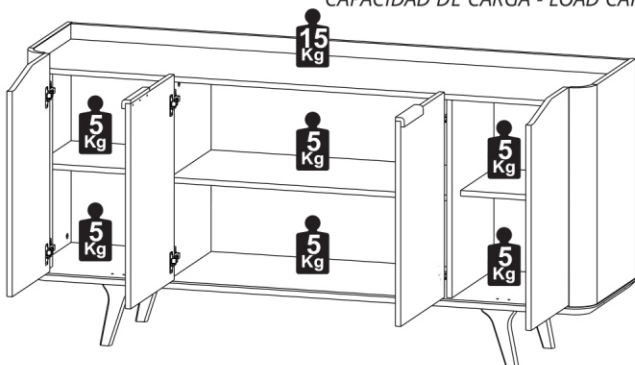

A CAPACIDADE DE CARGA INDICADA É
DISTRIBUÍDA NAS ÁREAS DEMONSTRADAS.

LA CAPACIDAD DE CARGA INDICADA ES
DISTRIBUIDA EN ZONAS DEMONSTRADAS.
THE INDICATED LOAD CAPACITY IS
DISTRIBUTED IN THE SHOWN AREAS.

ASPECTO FINAL

ASPECTO FINAL - FINAL ASPECT

