

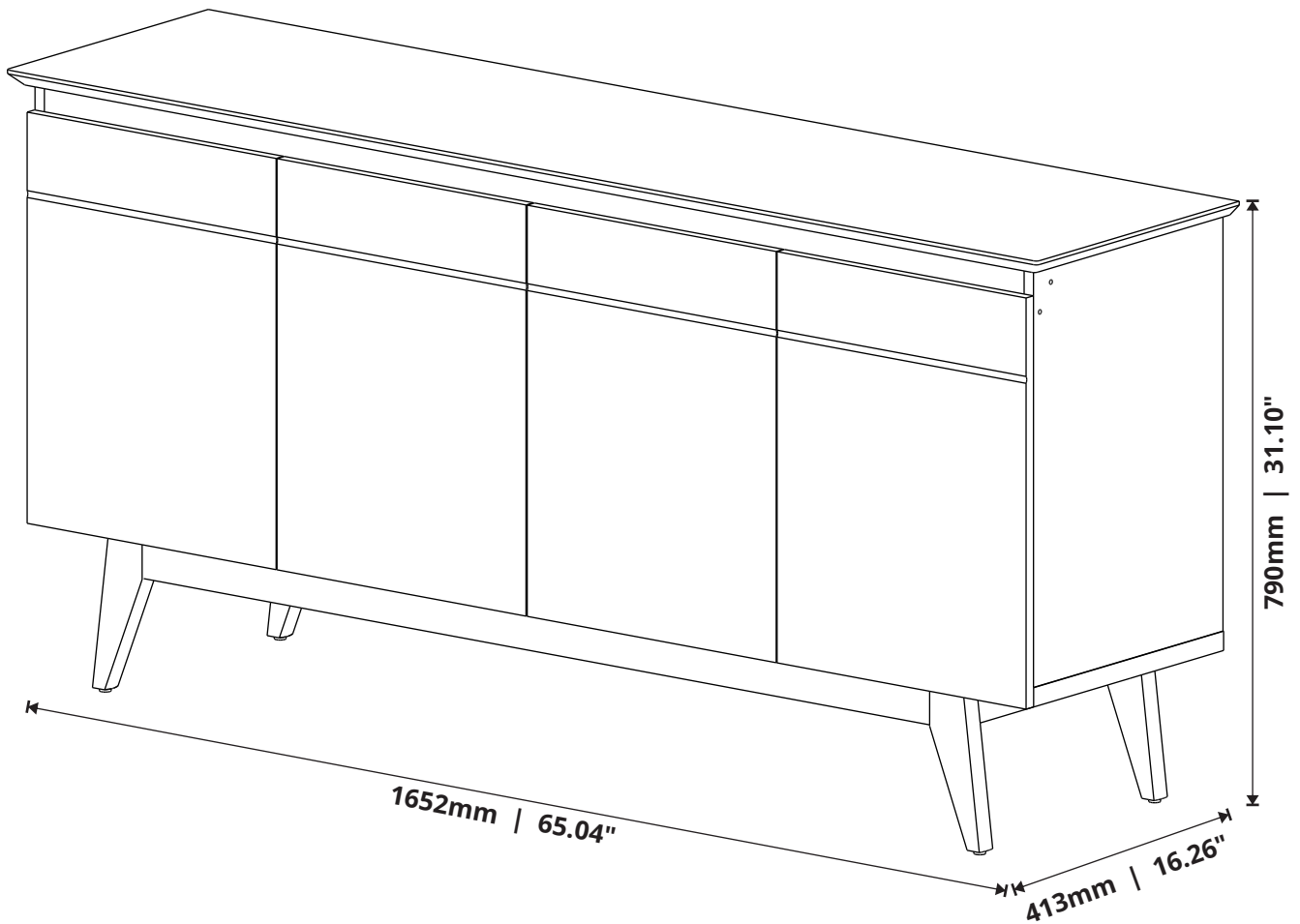

Buffet Classic 4P
Classic 4P Sideboard
Aparador Classic 4P (Consola)



ACESSÓRIOS

ACCESSORIES - ACCESORIOS

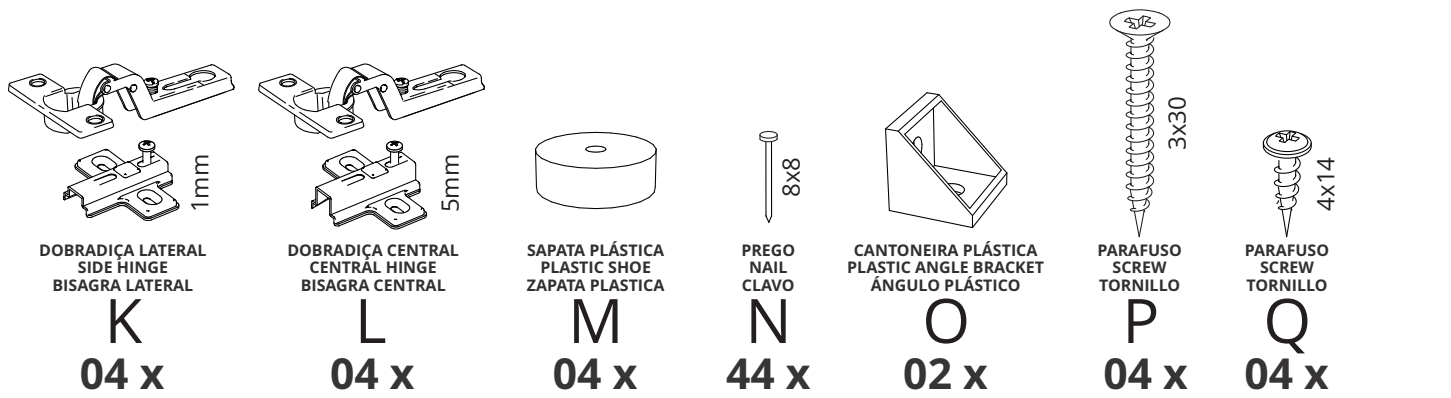
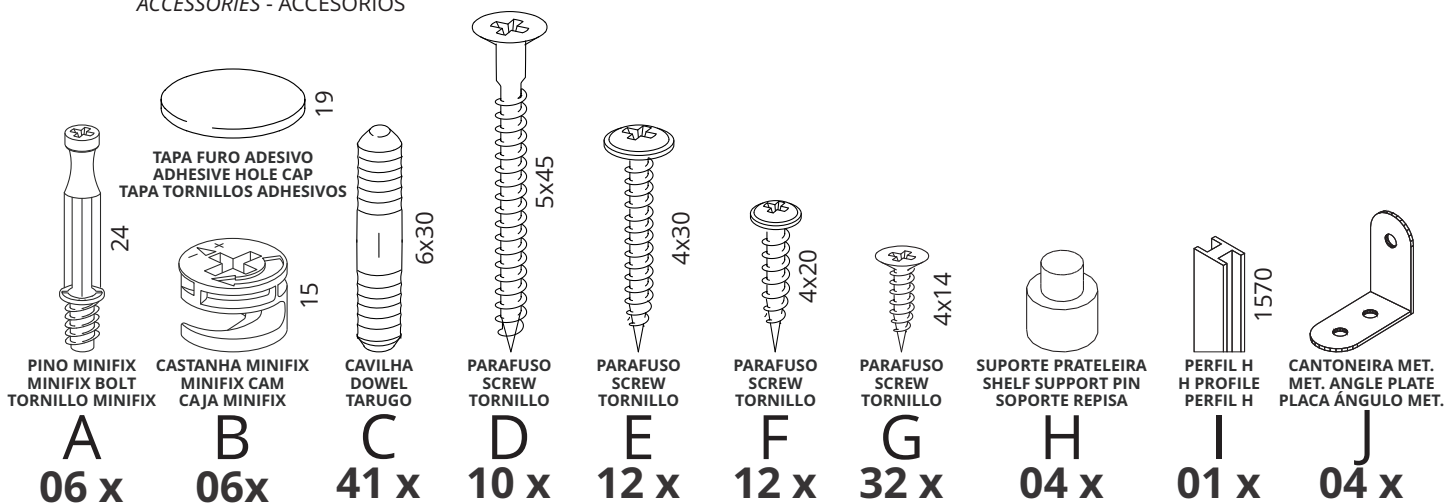

CAPACIDADE DE CARGA

LOAD CAPACITY - CAPACIDAD DE CARGA



A CAPACIDADE DE CARGA INDICADA É DISTRIBUÍDA NAS ÁREAS DEMONSTRADAS.

THE INDICATED LOAD CAPACITY IS DISTRIBUTED IN THE SHOWN AREAS.

LA CAPACIDAD DE CARGA INDICADA ES DISTRIBUIDA EN ZONAS DEMONSTRADAS.

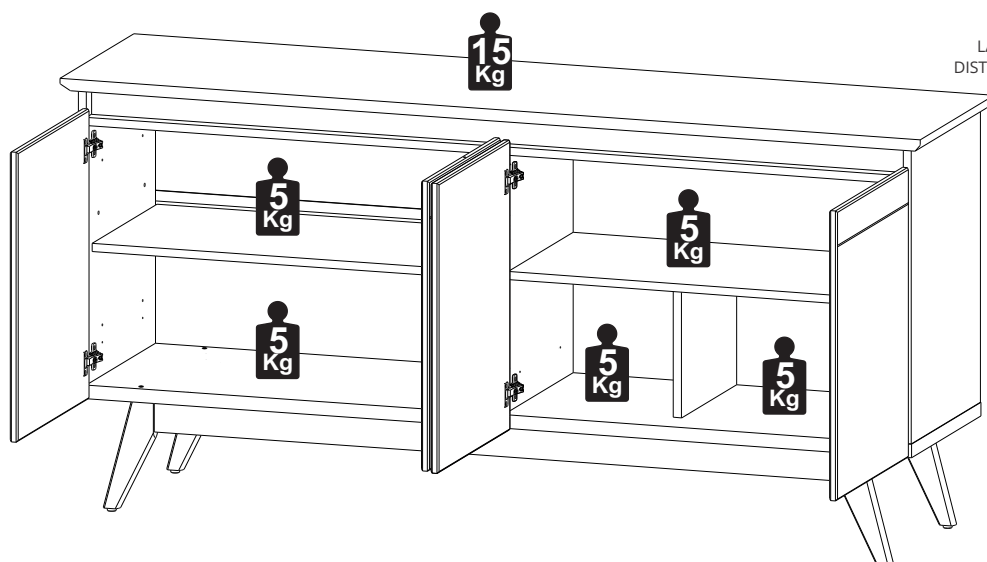

CONSERVANDO O SEU MÓVEL / MAINTAINING YOUR FURNITURE / MANTENIENDO SU MOBILIARIO

LIMPEZA DO MÓVEL / CLEANING THE FURNITURE / LIMPIANDO SU MOBILIARIO

Na remoção da poeira utilizar flanela limpa e levemente umedecida, em seguida flanela seca para remoção da umidade.

To remove dust use a clean flannel slightly moistened and afterwards a dry flannel to remove the humidity.

Para limpiar el polvo utiliza una flanela limpia y humedecida y después una flanela seca para quitar la humedad.

RECOMENDAÇÕES DE USO / USE RECOMMENDATIONS / RECOMENDACIONES DE USO

Não expor a luz solar e locais úmidos. Não movimentar o móvel.

Do not expose to sun light and humid places. Do not move your furniture.

No exponga a la luz solar y lugares húmedos. No mueva su mobiliario.

Este produto tem 6 meses de garantia contra defeito de fabricação.

This product has 6 months warranty against production defect.

Este producto tiene garantía de 6 meses contra defecto de fabricación.

PEÇAS

PIECES - PIEZAS

PORTUGUÊS

- 01- Pé Mad.
- 02- Pé Mad.
- 03- Travessa Menor
- 04- Travessa Maior
- 05- Base
- 06- Lateral Esq.
- 07- Lateral Interna
- 08- Divisória Interna
- 09- Lateral Dir.
- 10- Prateleira Fixa
- 11- Régua Puxador
- 12- Régua Puxador
- 13- Tampo
- 14- Porta
- 15- Porta
- 16- Prateleira Móvel
- F1- Fundo

ENGLISH

- 01- Wodden Leg
- 02- Wodden Leg
- 03- Smaller Frame
- 04- Bigger Frame
- 05- Base
- 06- Left Side
- 07- Inner Side
- 08- Inner Partition
- 09- Right Side
- 10- Fixed Shelf
- 11- Handle Frame
- 12- Handle Frame
- 13- Top
- 14- Door
- 15- Door
- 16- Mobile Shelf
- F1- Back

ESPAÑOL

- 01- Pie Mad.
- 02- Pie Mad.
- 03- Trabajo Menor
- 04- Trabajo Mayor
- 05- Base
- 06- Lado Izq.
- 07- Lado Interno
- 08- Partición Interna
- 09- Lado Der.
- 10- Repisa Fija
- 12- Regla Tirador
- 12- Regla Tirador
- 13- Cubierta
- 14- Puerta
- 15- Puerta
- 16- Repisa Móvil
- F1- Fondo

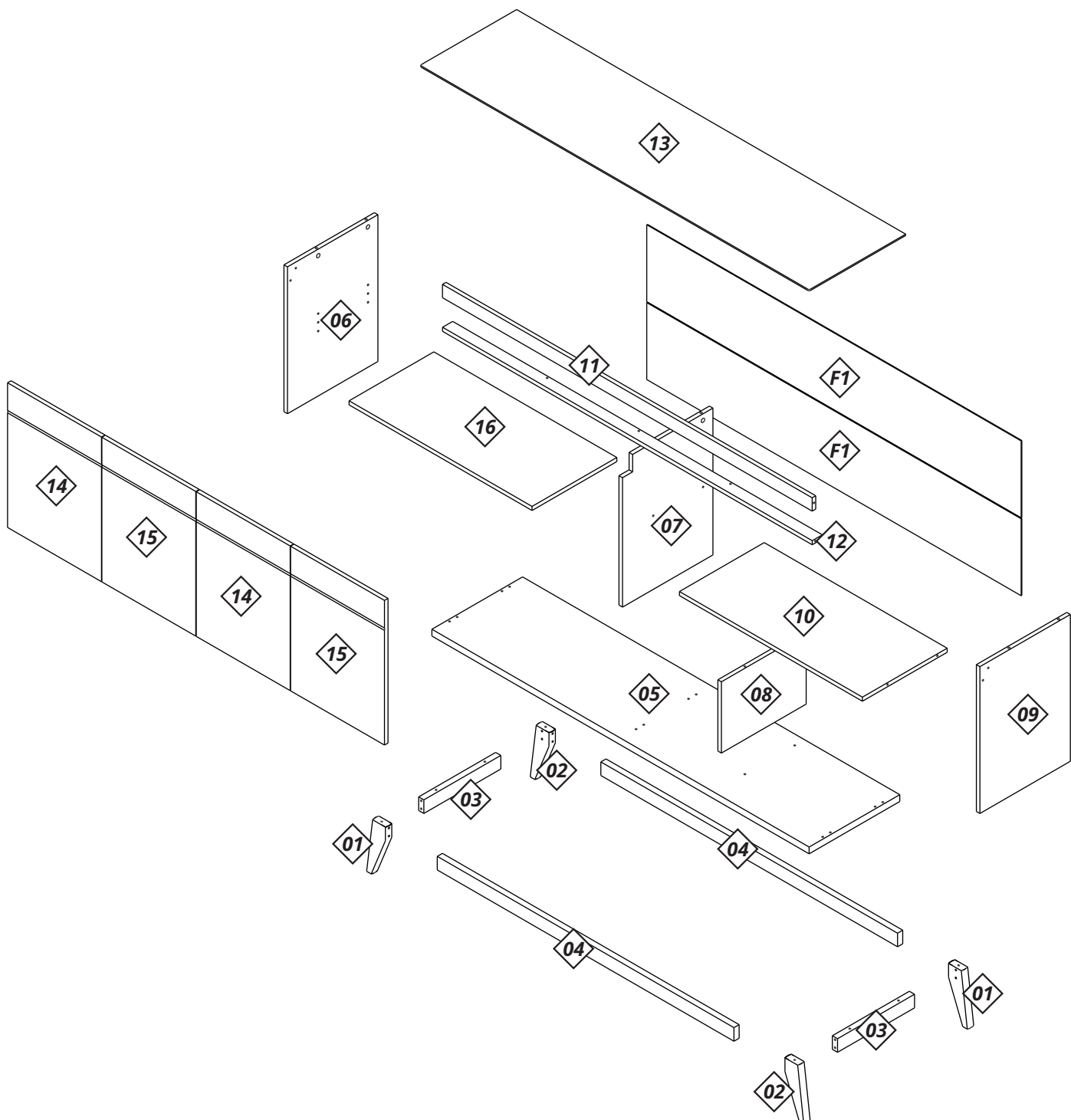

PRÉ-MONTAGEM

PRE ASSEMBLY - PRÉ-MONTAJE

IMPORTANTE

ATTENTION - IMPORTANTE

A MONTAGEM DEVE SER REALIZADA POR UM PROFISSIONAL DE MONTAGEM.

ASSEMBLY MUST BE CARRIED OUT BY AN ASSEMBLY PROFESSIONAL.

EL MONTAJE DEBE SER HECHO POR UN MONTADOR DE MUEBLES.

1

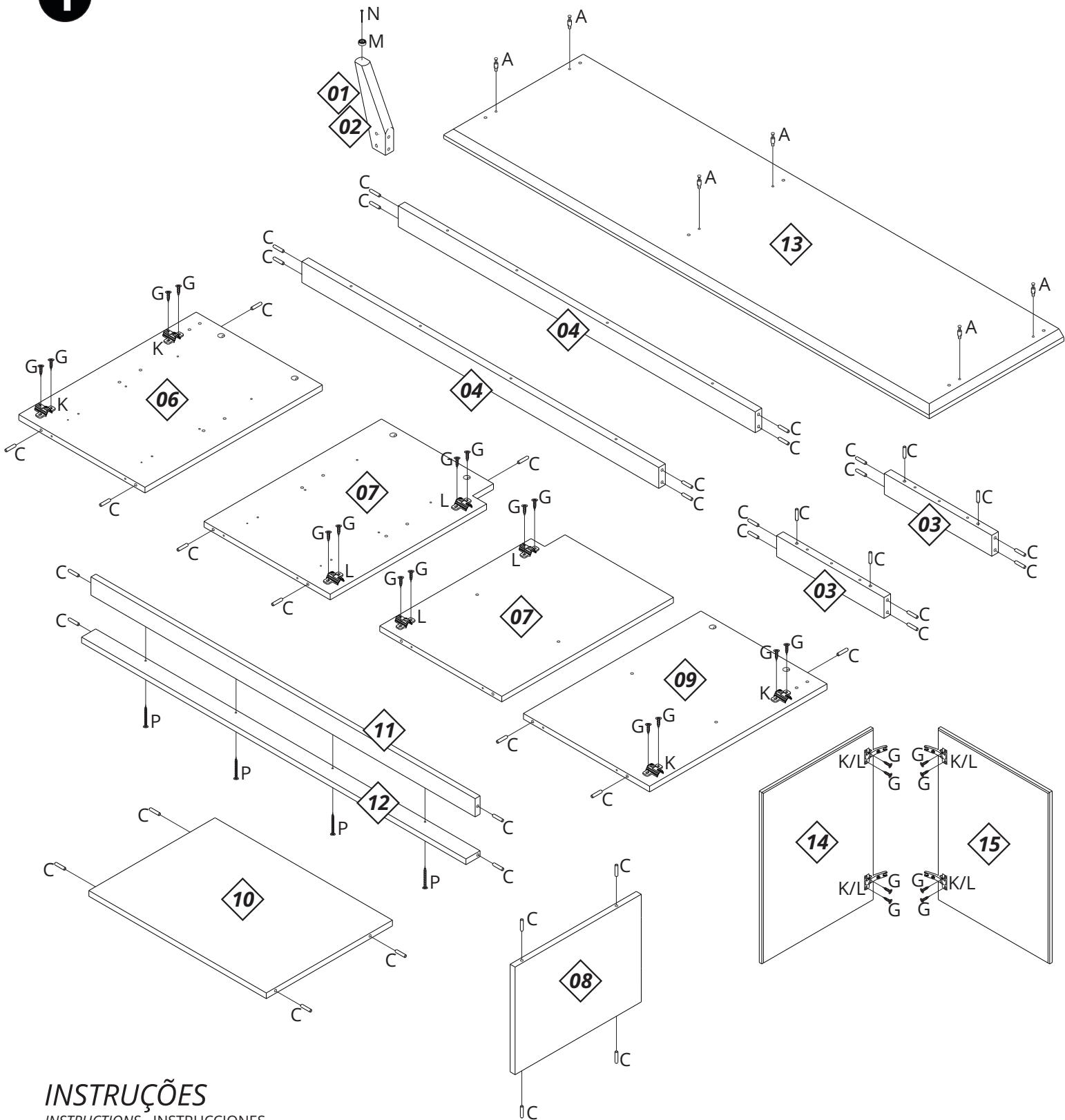

INSTRUÇÕES

INSTRUCTIONS - INSTRUCCIONES

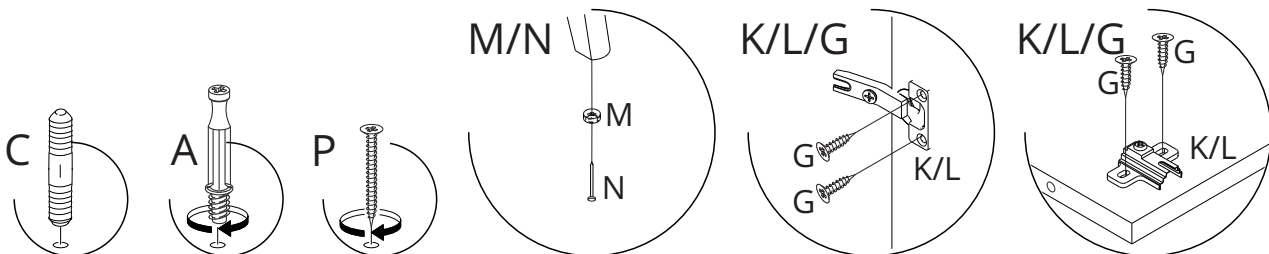

MONTAGEM

ASSEMBLY - MONTAJE

1

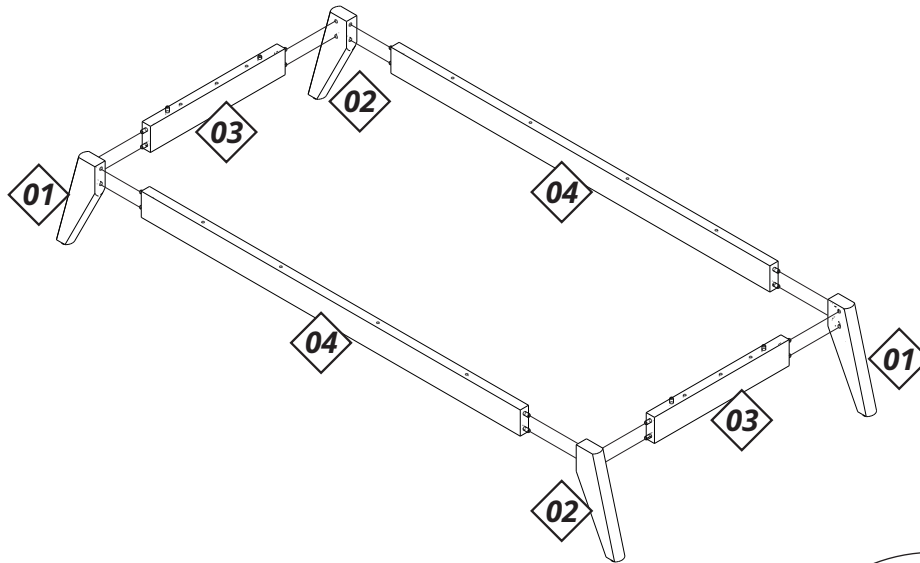

2

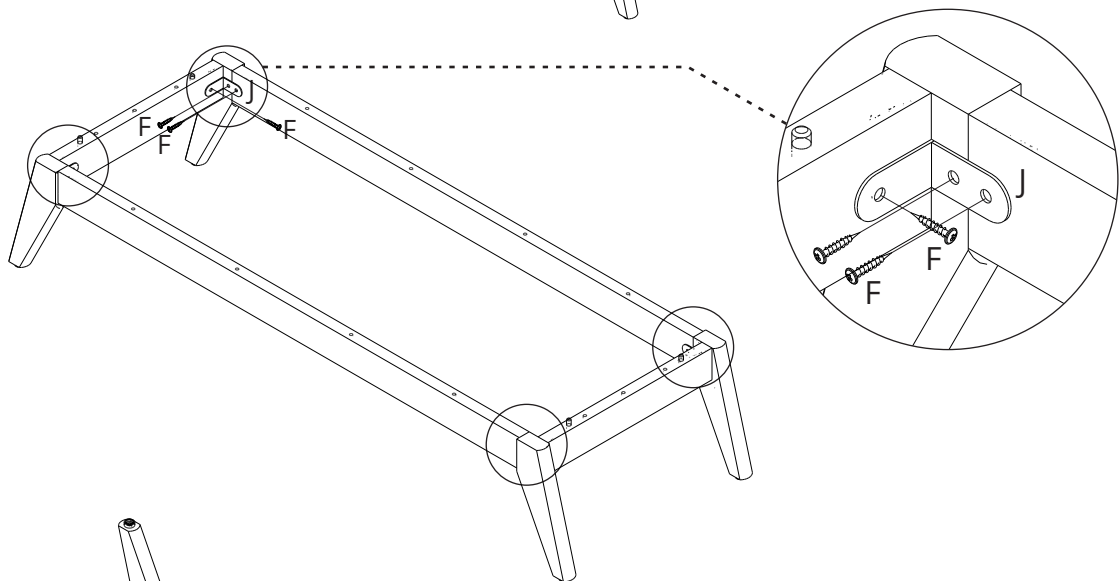

3

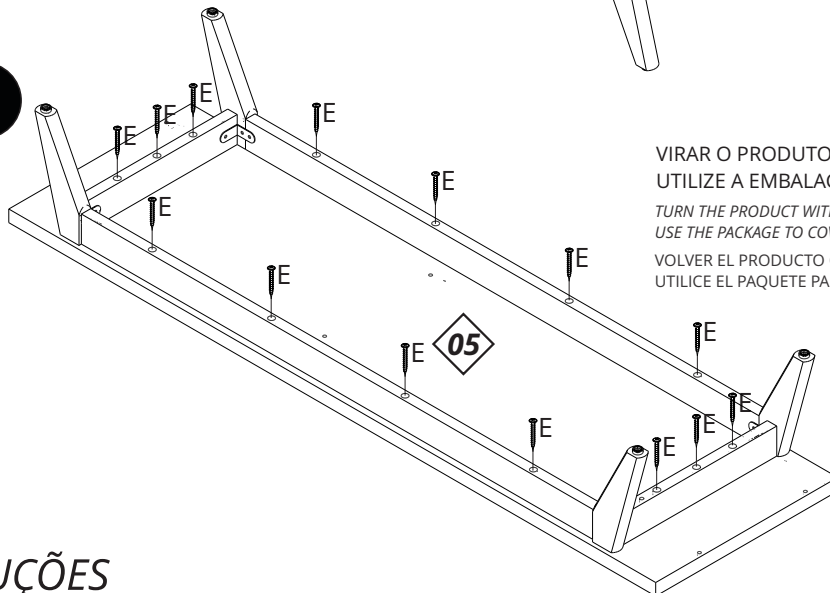

VIRAR O PRODUTO COM O BASE (05) VOLTADA AO CHÃO,
UTILIZE A EMBALAGEM PARA FERRAR O PISO E EVITAR DANOS À PINTURA.

TURN THE PRODUCT WITH THE BASE (05) BACK TO THE FLOOR,
USE THE PACKAGE TO COVER THE FLOOR AND AVOID DAMAGE TO THE FINISHING.

VOLVER EL PRODUCTO CON LA BASE (05) DE VUELTA AL SUELO,
UTILICE EL PAQUETE PARA CUBRIR EL SUELO Y EVITE DAÑOS A LA PINTURA.

INSTRUÇÕES

INSTRUCTIONS - INSTRUCCIONES

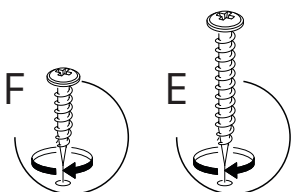

MONTAGEM

ASSEMBLY - MONTAJE

4

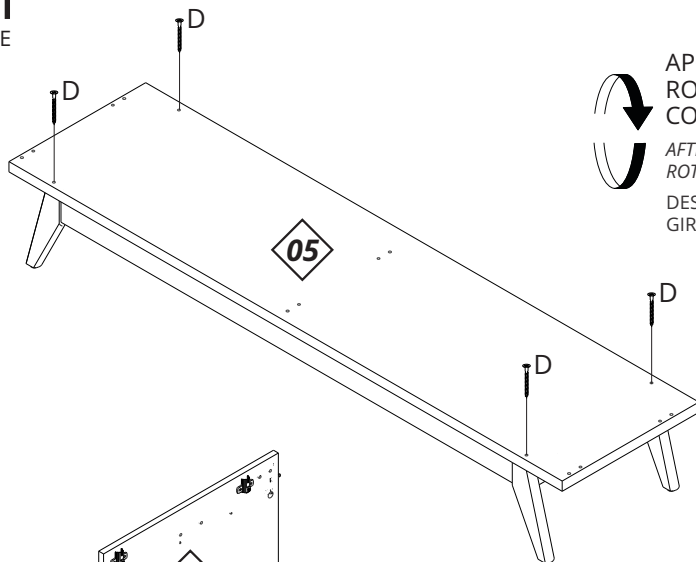

APÓS A MONTAGEM DO PASSO "3",
ROTACIONAR O CONJUNTO PARA
CONTINUAR O PROCESSO.

AFTER THE ASSEMBLY OF THE STEP "3",
ROTATE THE SET TO CONTINUE THE PROCESS.

DESPUÉS DE LA ASAMBLEA DEL PASO "3",
GIRAR EL CONJUNTO PARA CONTINUAR EL PROCESO.

5

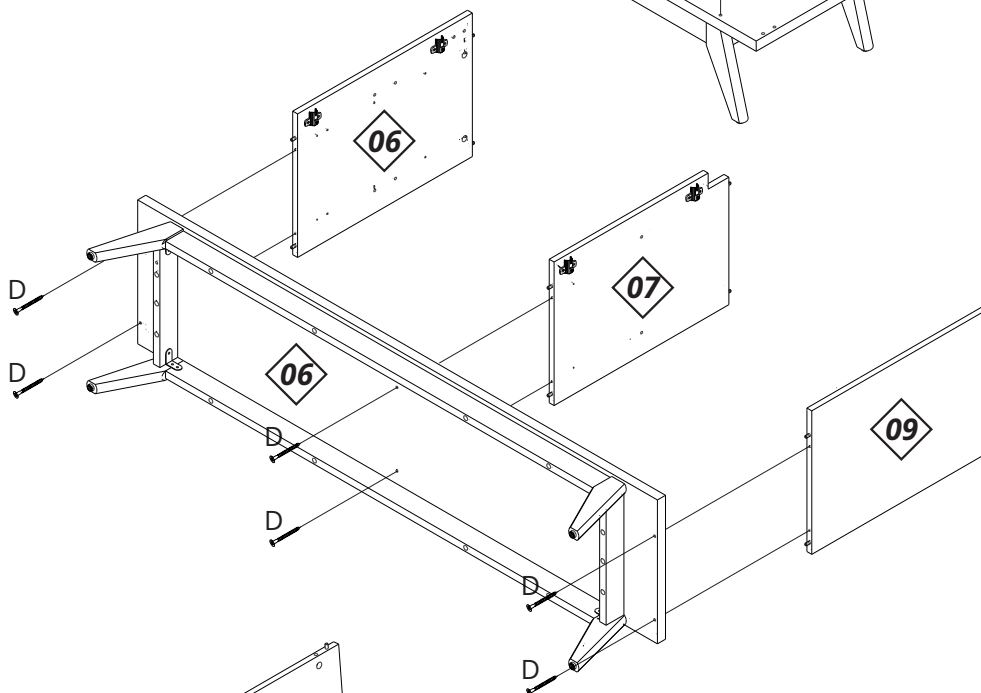

6

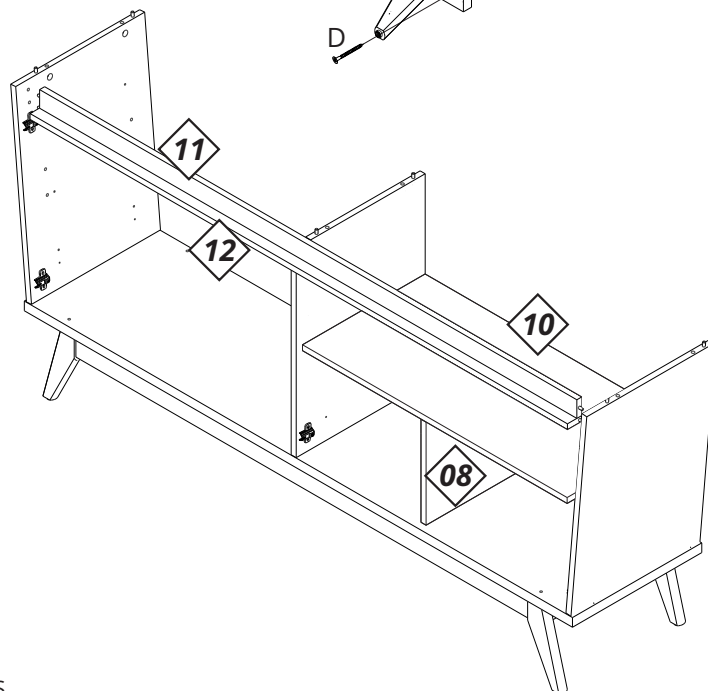

INSTRUÇÕES

INSTRUCTIONS - INSTRUCCIONES

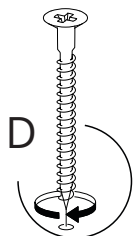

MONTAGEM

ASSEMBLY - MONTAJE

7

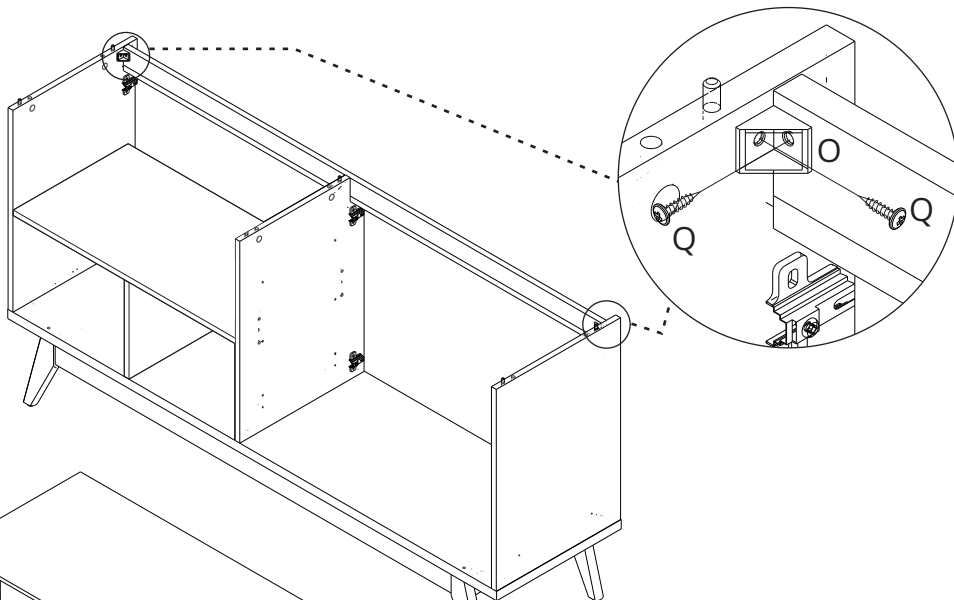

8

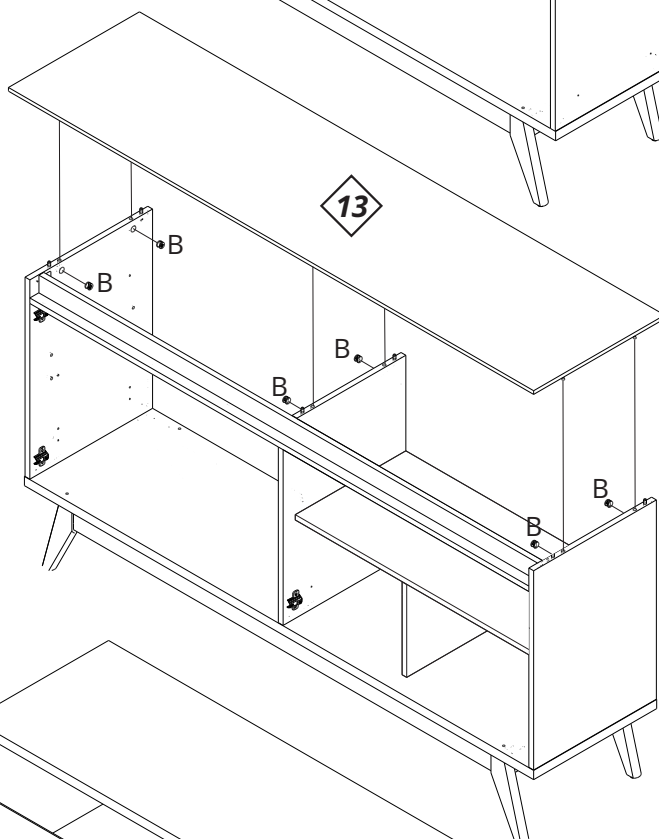

9

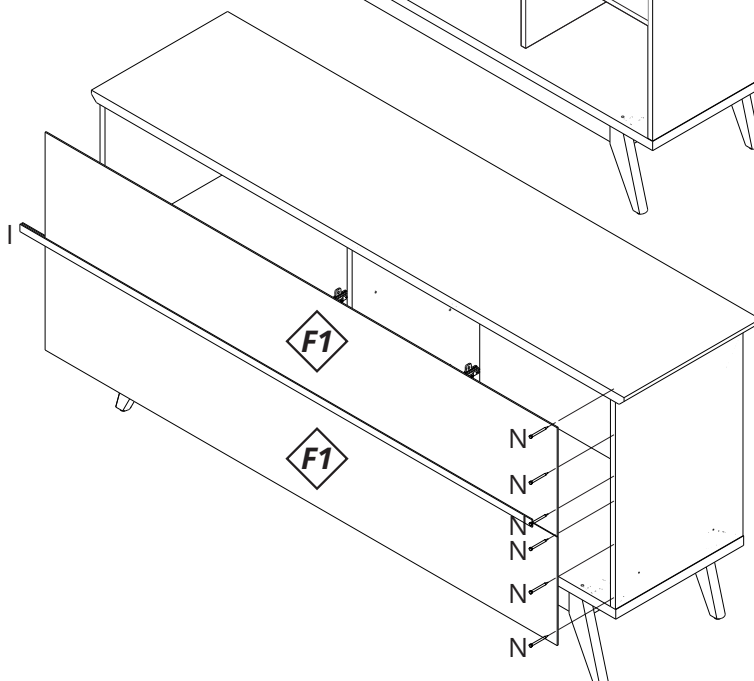

INSTRUÇÕES

INSTRUCTIONS - INSTRUCCIONES

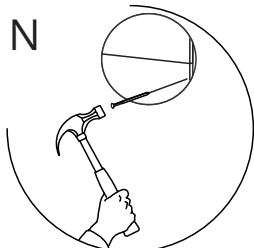
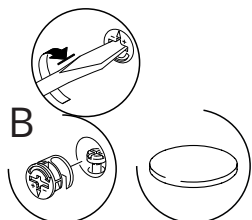

10

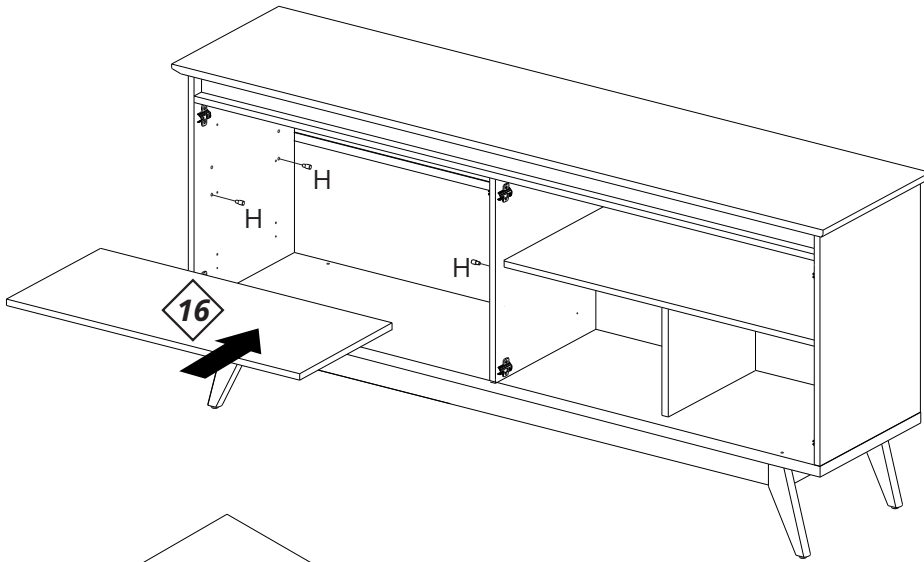

11

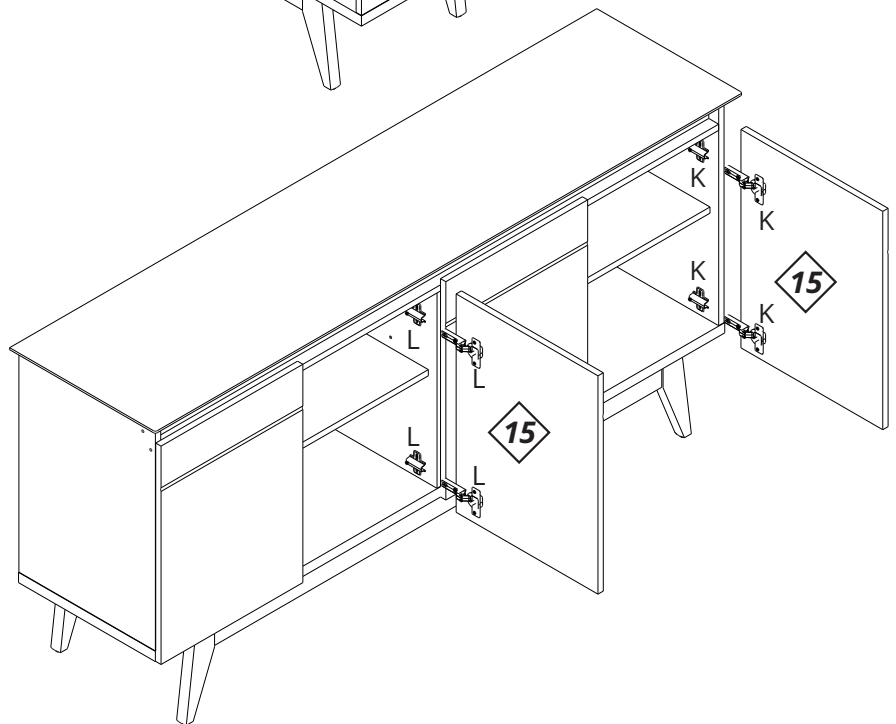
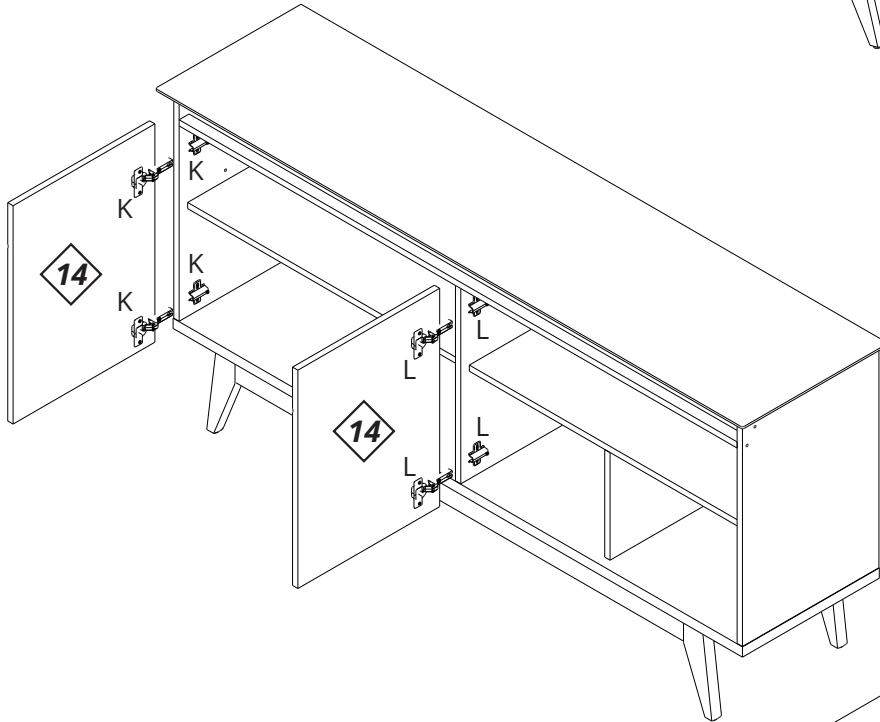

INSTRUÇÕES
INSTRUCTIONS - INSTRUCCIONES

