

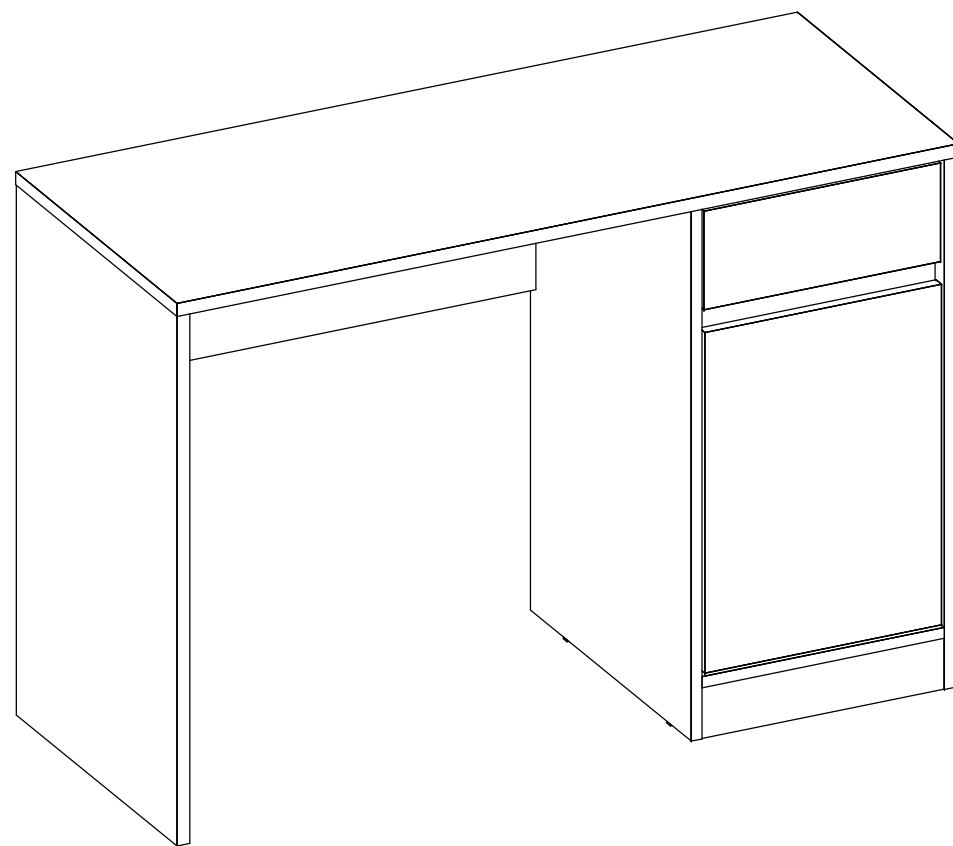

DEMÓBILE



29600 ESCRIVANINHA OFFICE 01PT 01 GAV MORADA

29600 OFFICE DESK 01D 01D MORADA

29600 ESCRITORIO 01P 01C MORADA

29600

**ESCRIVANINHA OFFICE 01PT 01 GAV MORADA
OFFICE DESK 01D 01D MORADA
ESCRITORIO 01P 01C MORADA**

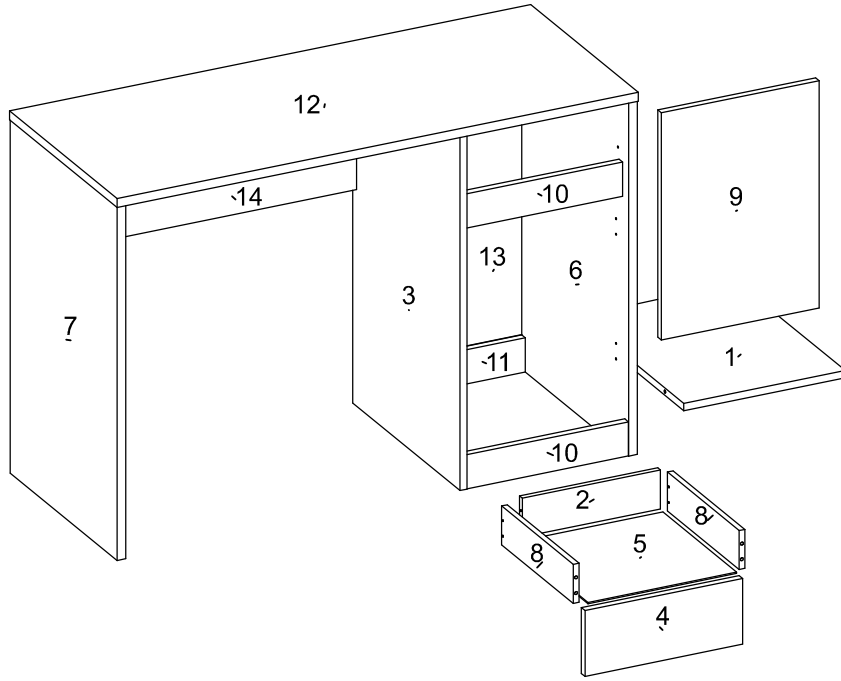

SEQ.	CODIGO	REF_01	REF_02	REF_03	REF_04	REF_05	REF_06	DESCRICAO	DESCRIPTION_EN	DESCRIPCION_ES	DIMENSÕES_MM	QTD
1	03193	138	03	-	-	-	-	BASE	BASE	BASE	448 X 338 X 15	1
2	06159	138	03	-	-	-	-	CONTRA FUNDO	DRAWER BACK	CONTRA FONDDO	289 X 80 X 12	1
3	08371	138	03	-	-	-	-	DIVISAO DIREITA	RIGHT DIVISION	DIVISION DERECHA	725 X 448 X 15	1
4	09207	136	03	-	-	-	-	FRENTE DE GAVETA	DRAWER FRONT	FRENTE DEL CAJON	330 X 135 X 15	1
5	10137	138	03	-	-	-	-	FUNDO GAVETA	DRAWER BASE	FONDO DEL CAJON	311 X 308 X 3	1
6	11460	136	03	-	-	-	-	LATERAL DIREITA	RIGHT SIDE PANEL	LATERAL DERECHA	725 X 448 X 18	1
7	11461	136	03	-	-	-	-	LATERAL ESQUERDA	LEFT SIDE PANEL	LATERAL IZQUIERDA	725 X 448 X 18	1
8	12034	138	03	-	-	-	-	LATERAL DE GAVETA	DRAWER SIDE	LATERAL DEL CAJON	300 X 80 X 12	2
9	14338	136	03	-	-	-	-	PORTA	DOOR	PUERTA	466 X 330 X 15	1
10	16423	152	03	-	-	-	-	RODAPE FRONTAL VISTA	BOTTOM BOARD FRONT	ZÓCALO FRONTAL	338 X 70 X 15	2
11	16424	20	20	-	-	-	-	RODAPE TRASEIRO	BOTTOM BOARD BACK	ZÓCALO TRASERO	338 X 70 X 15	1
12	19276	136	03	-	-	-	-	TAMPO	TOP	TAPA	1090 X 450 X 18	1
13	20469	138	03	-	-	-	-	TRASEIRO	BACK PANEL	TRASERO	670 X 365 X 3	1
14	27072	136	03	-	-	-	-	PAINEL TRASEIRO	REAR PANEL	PANEL TRASERO	699 X 281 X 15	1

DEMÓBIL Indústria de Móveis Ltda.
Rua : Jurutau, 1350 - Pq. Industrial II.
Cep.: 86703-070
Arapongas - PR - Brasil
demobile@demobile.com.br

CERTIFICADO 90 DIAS GARANTIA

- AVISOS**
- Ler atentamente as instruções do manual antes de iniciar a montagem do móvel.
 - A montagem deverá ser feita em superfície limpa e plana, aconselhamos forrar o chão com a embalagem do produto, para não danificar.
 - Os parafusos devem ser apertados periodicamente.
 - Evitar batidas e contato com objetos cortantes.
 - O peso máximo de carga informado refere-se a objetos distribuídos de maneira uniforme sobre toda área de contato da peça.

Limpeza e Conservação
Efetuar a limpeza somente com pano macio limpo e seco. Não Utilizar produtos abrasivos ou químicos.

Garantia
1.O fabricante responsabiliza-se apenas pelas peças do produto.
2.A montagem incorreta acarretará na perda da garantia e das assistências, desta forma o produto deverá ser montado por profissional qualificado.
3.Não estão cobertos pela garantia problemas que tenham origem na utilização inadequada do produto ou na exposição do mesmo a intempéries como: infiltrações, infestação de pragas em geral, aparecimento de mofo e outros, decorrentes do ambiente de instalação.

Assistência Técnica: Em caso de peças em assistência técnica é necessário que as mesmas sejam solicitadas junto a loja ou site no qual a compra do produto foi realizada.

- Warnings**
- Read the manual instructions carefully before starting to assemble the furniture.
 - The assembly must be done in clean and flat surface, we advise to put the product packaging on the floor, not to damage it during the assembling.
 - The screws must be tightened periodically.
 - Avoid hitting and contacting sharp objects.
 - The payload informed refers to the objects distributed all over the piece contact area.
- Cleaning and conservation**
Clean the product just with a soft, cleaned and dry cloth. Do not use abrasive or chemicals products.
- Warranty**
1.The manufacturer is only responsible for product parts.
2.Incorrect assembling will make you lost the guarantee and assistance, in this way the product must be assembled by qualified professional.
3.It is Not covered by the warranty problems caused by an inappropriate use of the product or product exposure even in bad weather, such as: infiltrations, pest infestation in general, appearance of mold and others, caused by the installation environment.

Acessórios / Accessories / Accesorios

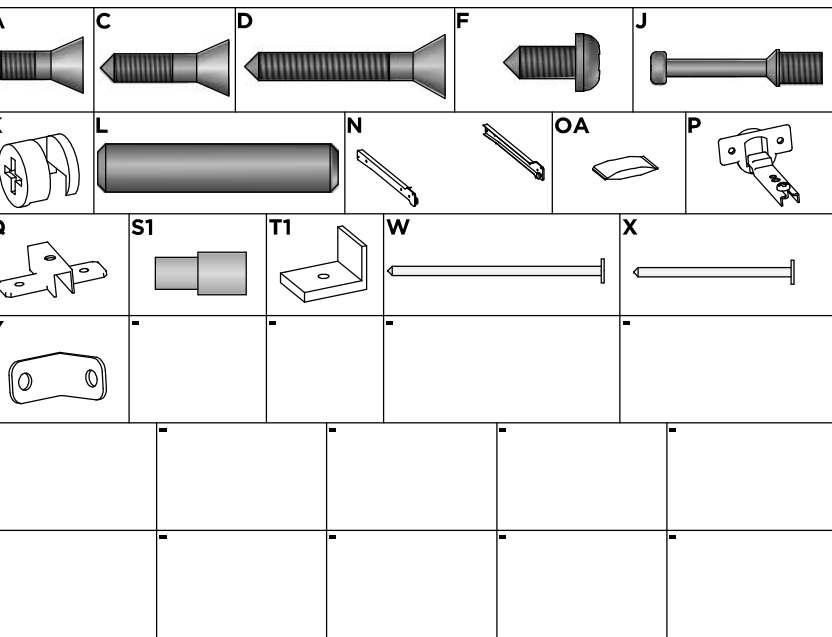

LISTA DE ACESSÓRIOS / LIST OF ACCESSORIES / LISTA DE ACCESORIOS

SEQ.	CODIGO	DESCRIÇÃO	DESCRIPTION_EN	DESCRIPCION_ES	QTD.
A	9905002	PARAFUSO 3.5 X 12 MM CHATA PHILIPS	PHILIPS FLAT HEAD SCREW	TORNILLO CHATA PHILIPS	14
C	9905004	PARAFUSO 3.5 X 16 MM CHATA PHILIPS	PHILIPS FLAT HEAD SCREW	TORNILLO CHATA PHILIPS	6
D	9905018	PARAFUSO 3.5 X 25 MM CHATA PHILIPS	PHILIPS FLAT HEAD SCREW	TORNILLO CHATA PHILIPS	4
F	9905007	PARAFUSO 4 X 12 MM PANELA PHILIPS	PANHEAD SCREW	TORNILHO CABEZERA DE OLHA	8
J	9920029	PINO MINIFIX 12 MM	MINIFIX PIN	PINO MINIFIX	18
K	9920009	CASTANHA MINIFIX 12 MM	MINIFIX CHESTNUT	LOS SIMPSON	18
L	9920011	CAVILHAS 6 X 30 MM	WOODEN PEG	CLAVIJA DE MADERA	16
N	9913009	CORREDICA 300 MM METAL LIGHT	METAL SLIDE	RIEL METALICO	1
OA	9912006	SACHET DE COLA	GLUE	COLA	1
P	9920020	DOBRADICA ALTA 26 MM ESTAMPADA	HINGE	BISAGRA	2
Q	9920004	CALCO DOBRADICA 12 MM	HINGE SUPPORT	SOPORTE DE BISAGRA	2
S1	9920040	SUPORTE PRATELEIRA 6 X 8	SHELF SUPPORT	SOPORTE DE ESTANTERIA	1
T1	9924007	MINI SAPATA L 12 MM	MINI SHOE	MINI ZAPATA	6
W	9906001	PREGO 12X12 MM	NAIL	CLAVO	6
X	9906002	PREGO 9X9 MM	NAIL	CLAVO	20
Y	9920006	CANTONEIRA METALICA 16 MM	METAL ANGLE BRACKET	ESQUINERAS METALICAS	4

- Advertencias**
- Lee atentamente las instrucciones del manual antes de empezar a armar los muebles.
 - El montaje debe hacerse en superficie limpia y plana, utilice el empaque del Producto para cubrir el piso.
 - Los tornillos deben ser apretados periódicamente
 - Evite golpear y chocar objetos punzantes
 - El peso máximo de carga tiene relación a los objetos distribuidos sobre toda el área de contacto de la pieza.

Limpeza y conservación
Limpiar solo con un trapo suave, limpio y seco
No utilice productos abrasivos o productos químicos

Garantía
1.El fabricante solo es responsable a las partes del producto.
2. Armar incorrectamente supone la pérdida de garantía y repuestos, de esta manera el producto debe ser ensamblado por profesional calificado
3.No es garantizado problemas derivados del uso inapropiado del producto, o exposición del producto al mal tiempo, como: infiltraciones, infestación de plagas en general, aparición de moho y otros.

Asistencia técnica: en caso de piezas rotas es necesario que sea solicitadas las mismas a la tienda o sitio web donde se compró el producto.

**COMPLETE MANUAL
MANUAL COMPLETO**

01

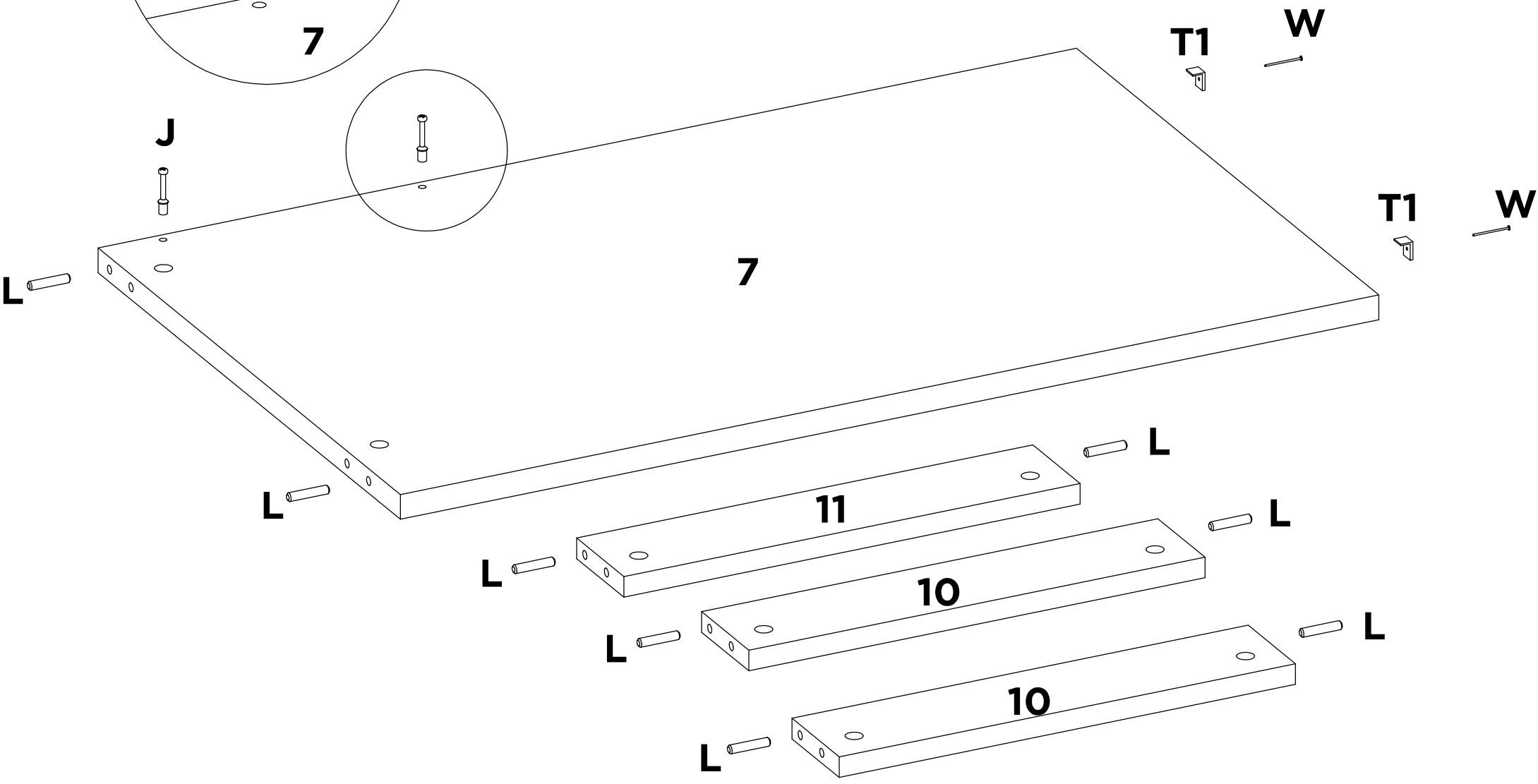
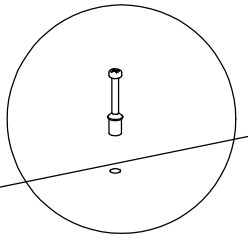
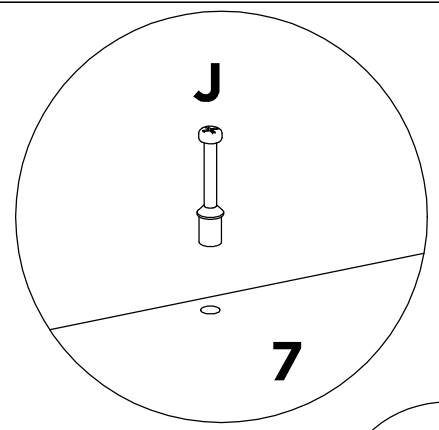

L	X8	J	X2	T1	X2	W	X2	-	-	-	-
----------	-----------	----------	-----------	-----------	-----------	----------	-----------	---	---	---	---

02

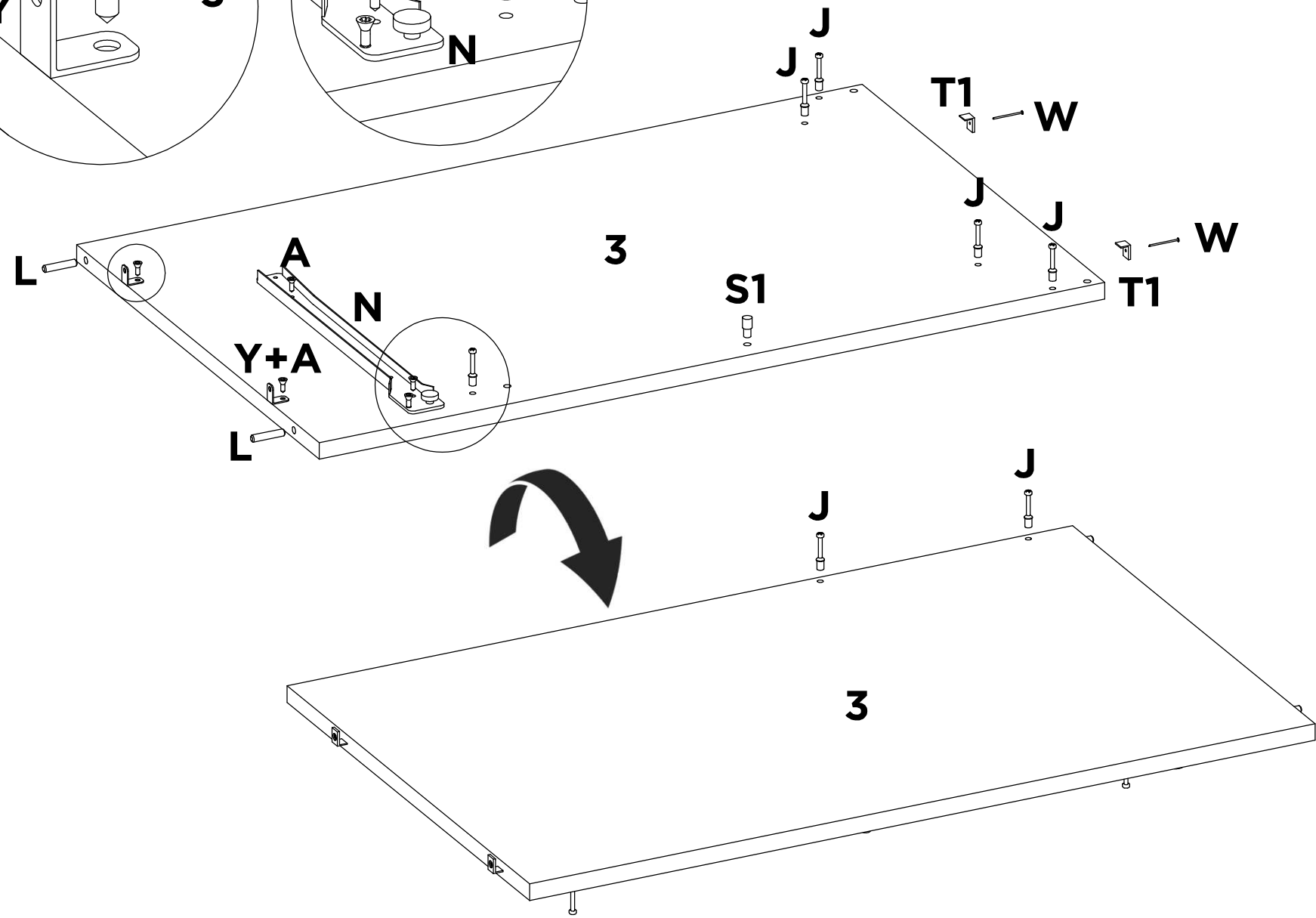
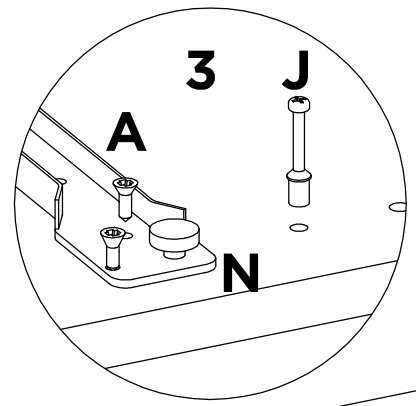
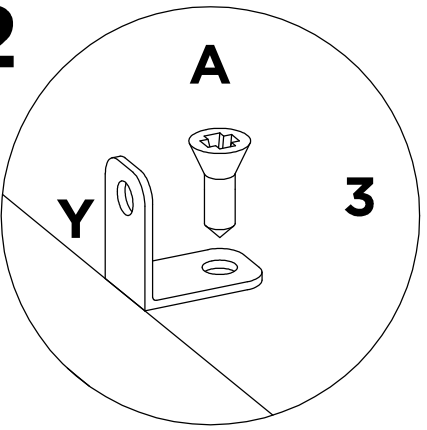

L	Y	A	N	S1	T1	W	J
X2	X2	X5	X1	X1	X2	X2	X7

03

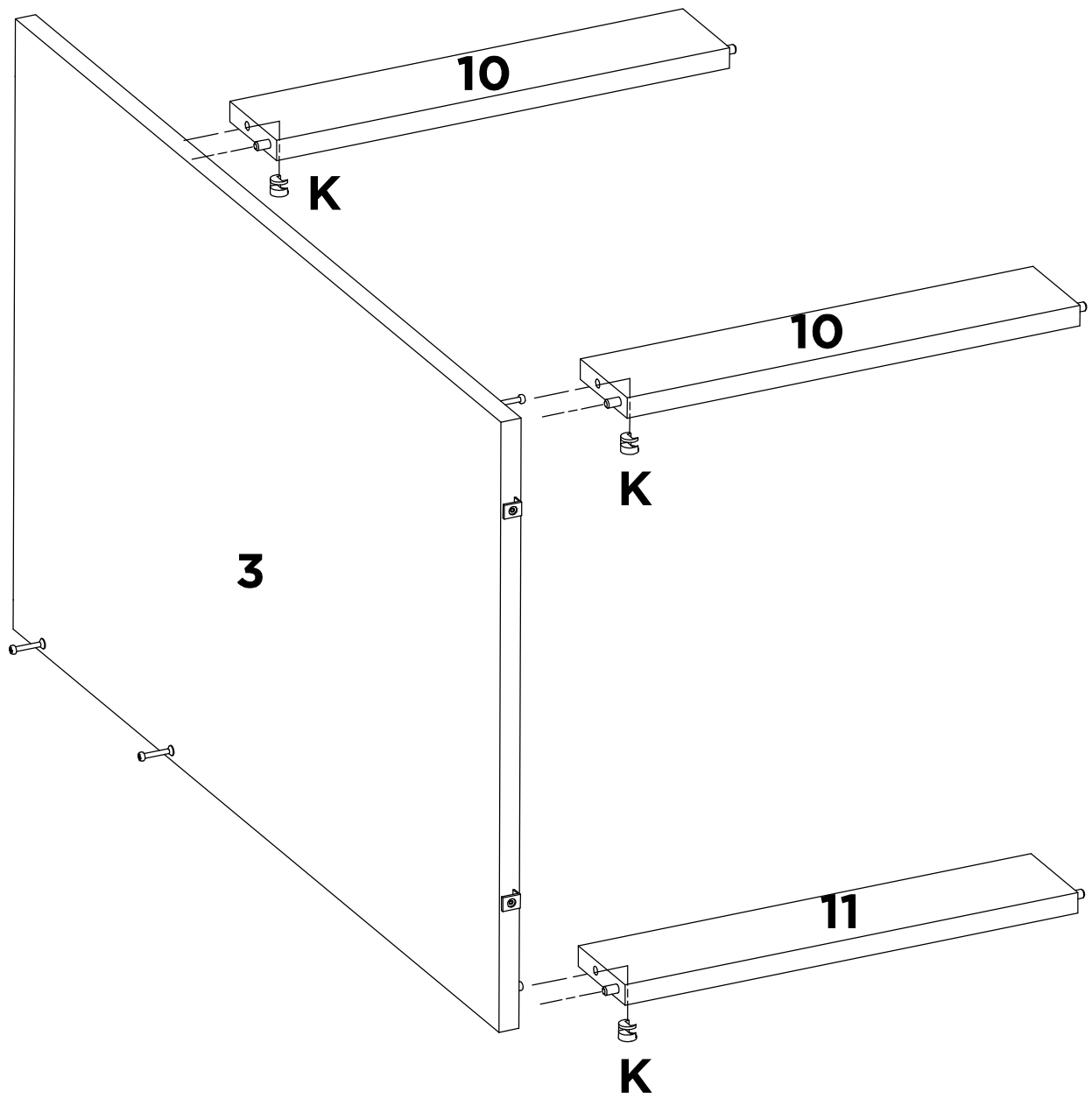

K	-	-	-	-	-	-	-
X3	-	-	-	-	-	-	-

04

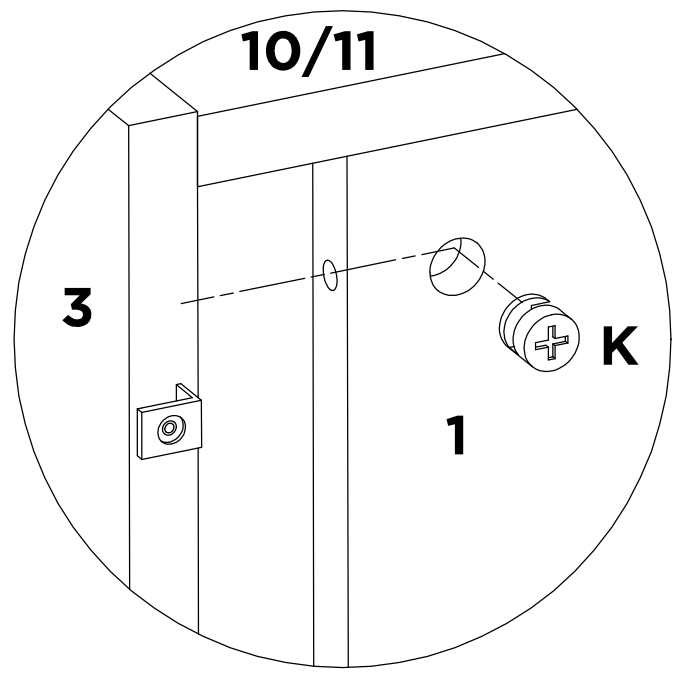
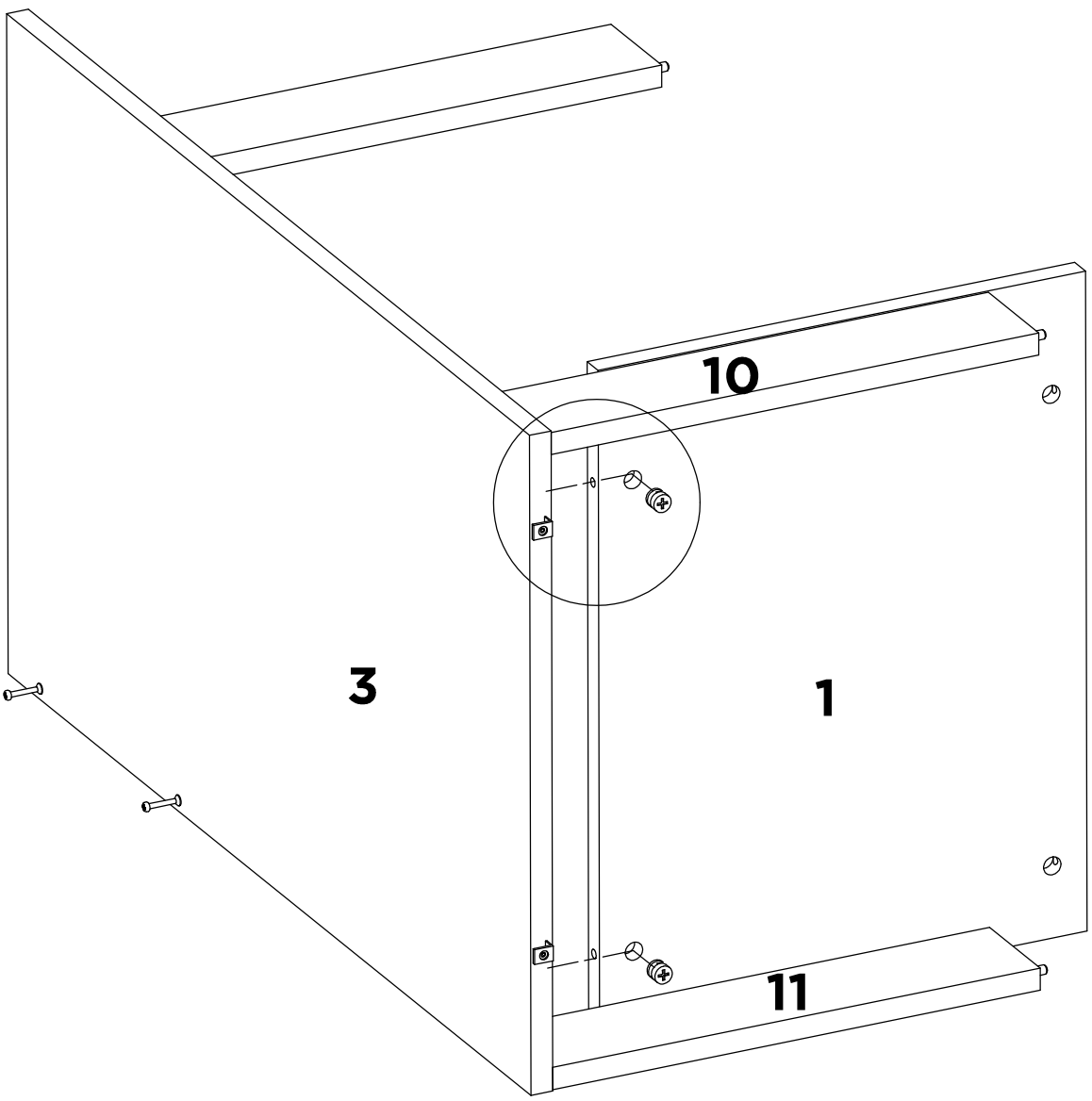

K	-	-	-	-	-	-	-
X2	-	-	-	-	-	-	-

05

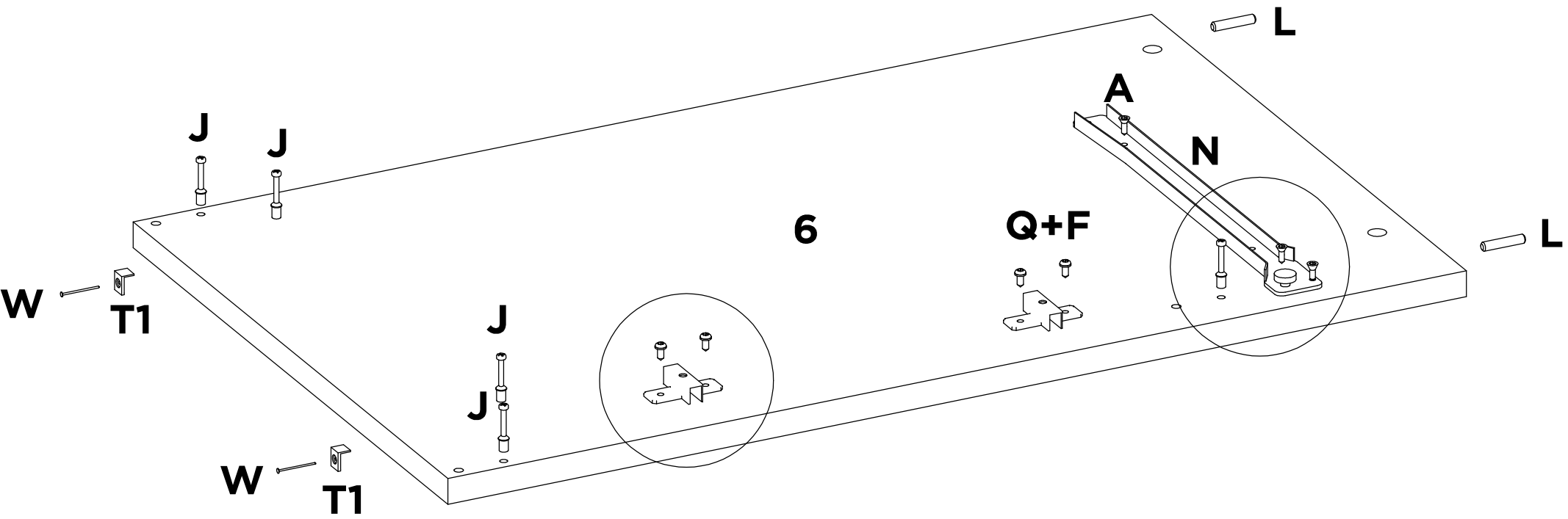
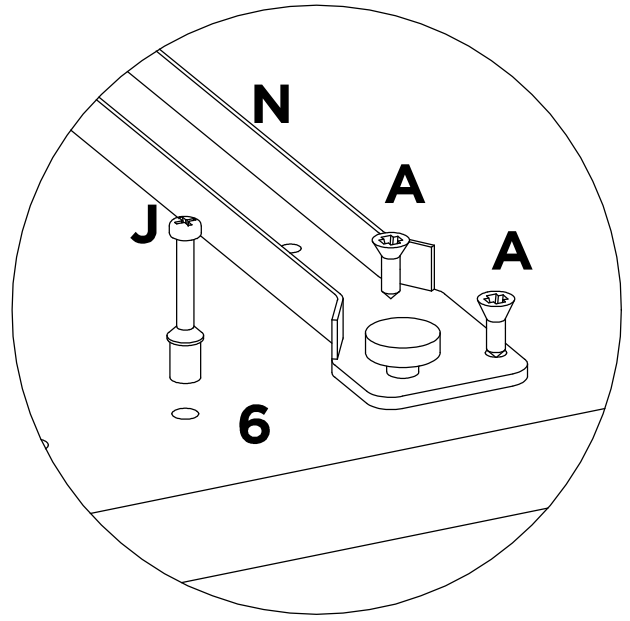
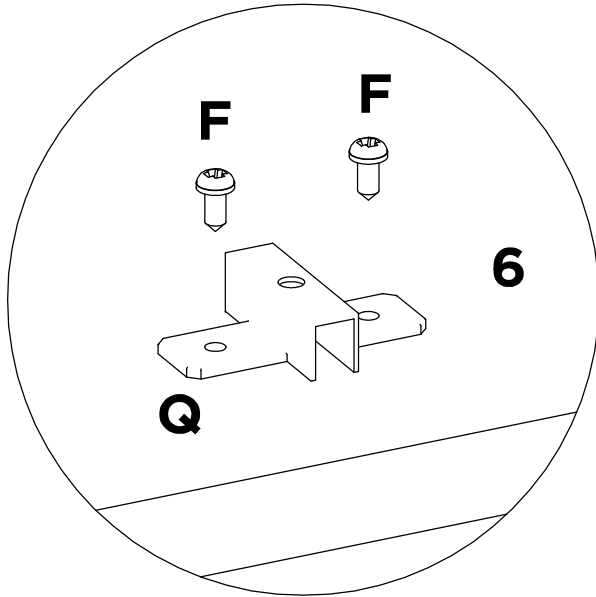

W	J	Q	F	A	N	L	-
X2	X5	X2	X4	X3	X1	X2	-

06

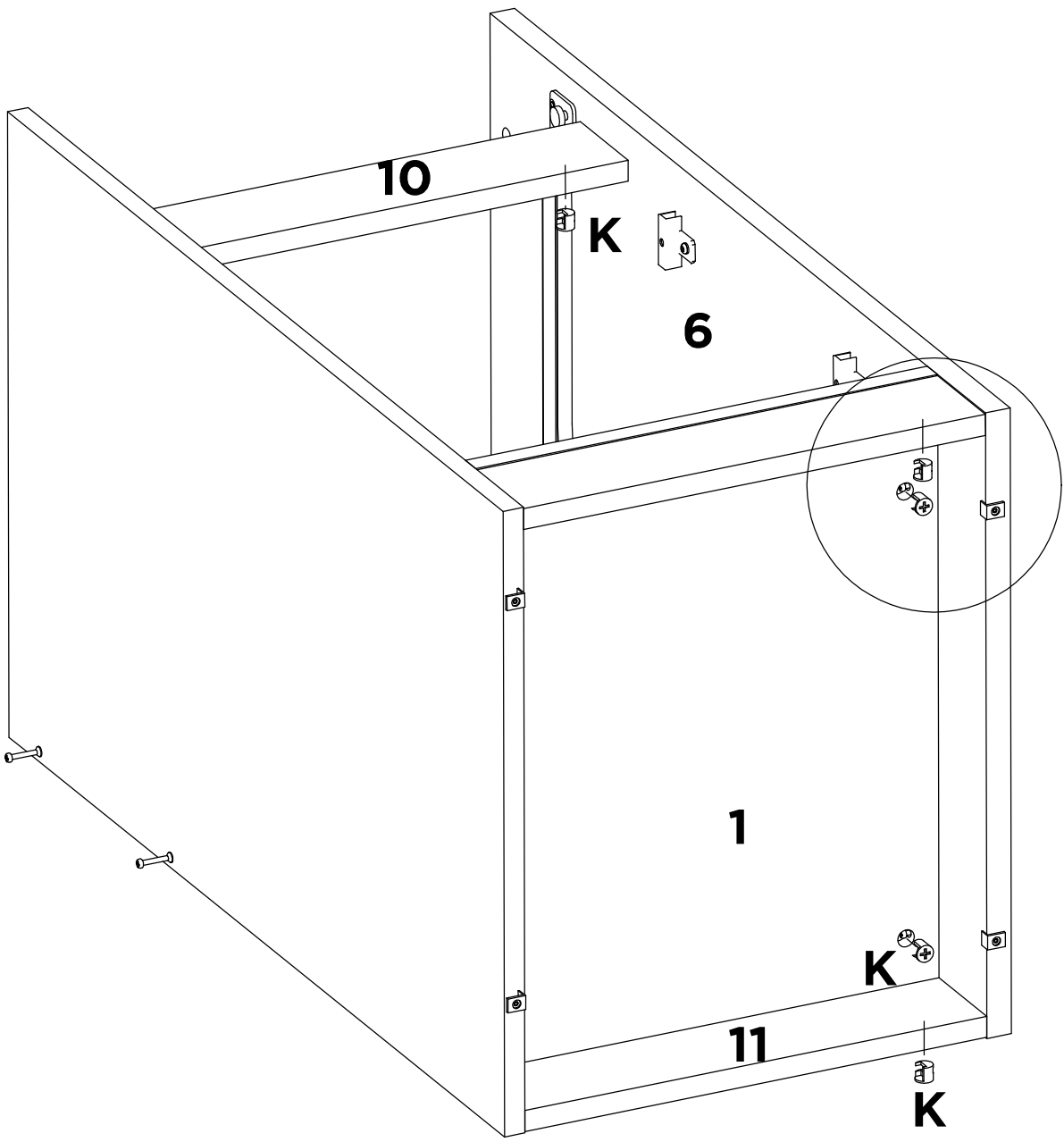

10/11
K
1 K 6

K	-	-	-	-	-	-	-
X5	-	-	-	-	-	-	-

07

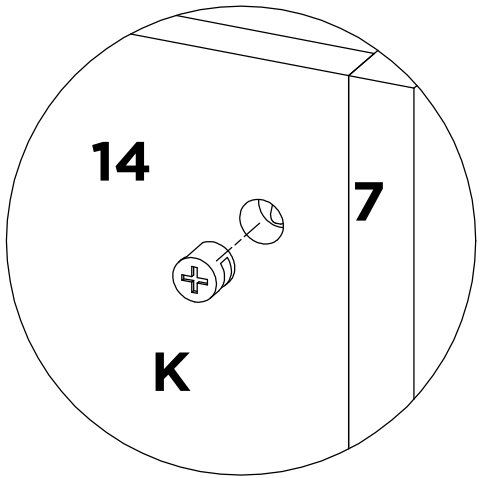
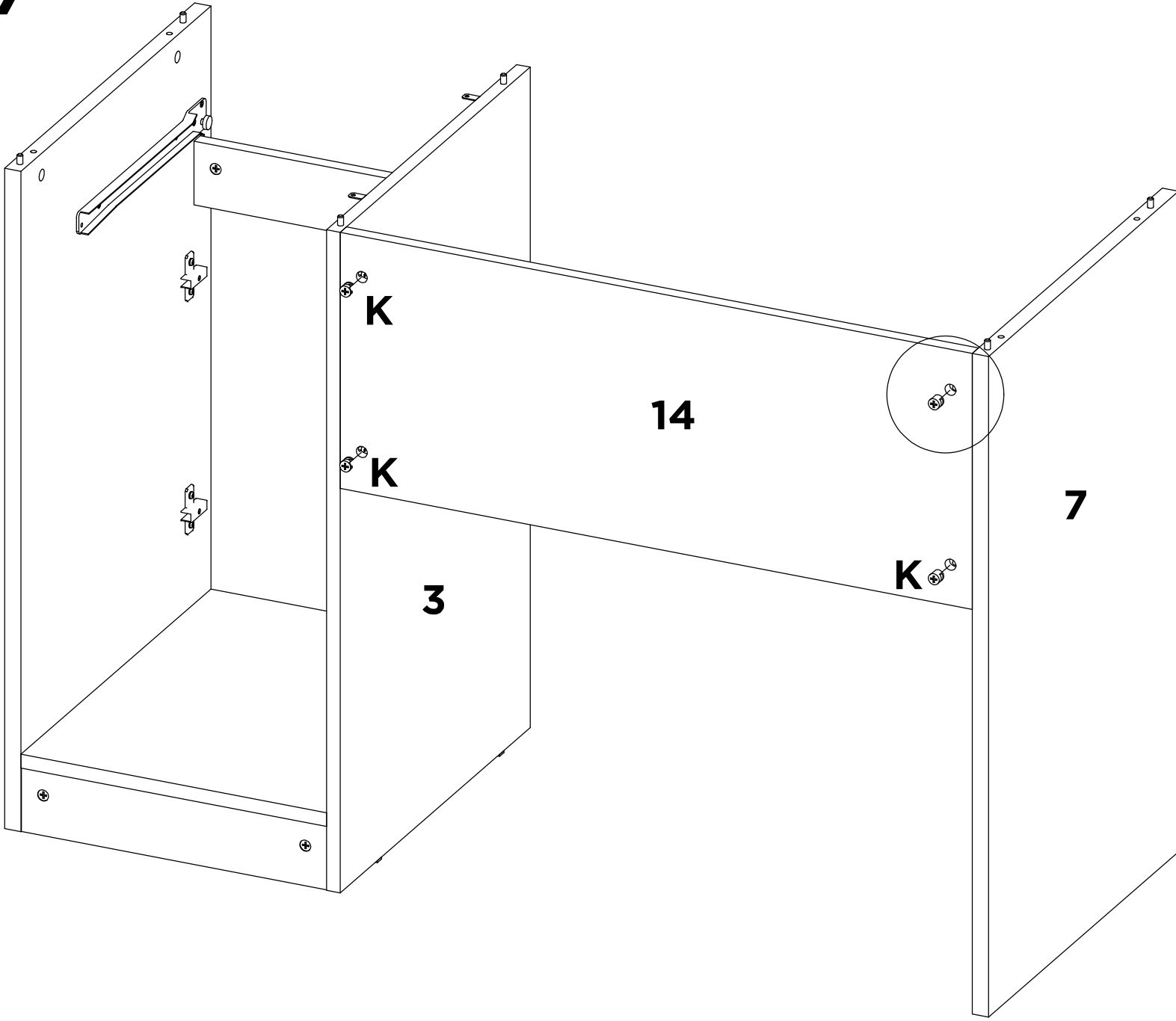

K	-	-	-	-	-	-	-
X4	-	-	-	-	-	-	-

08

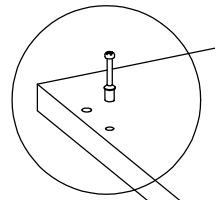
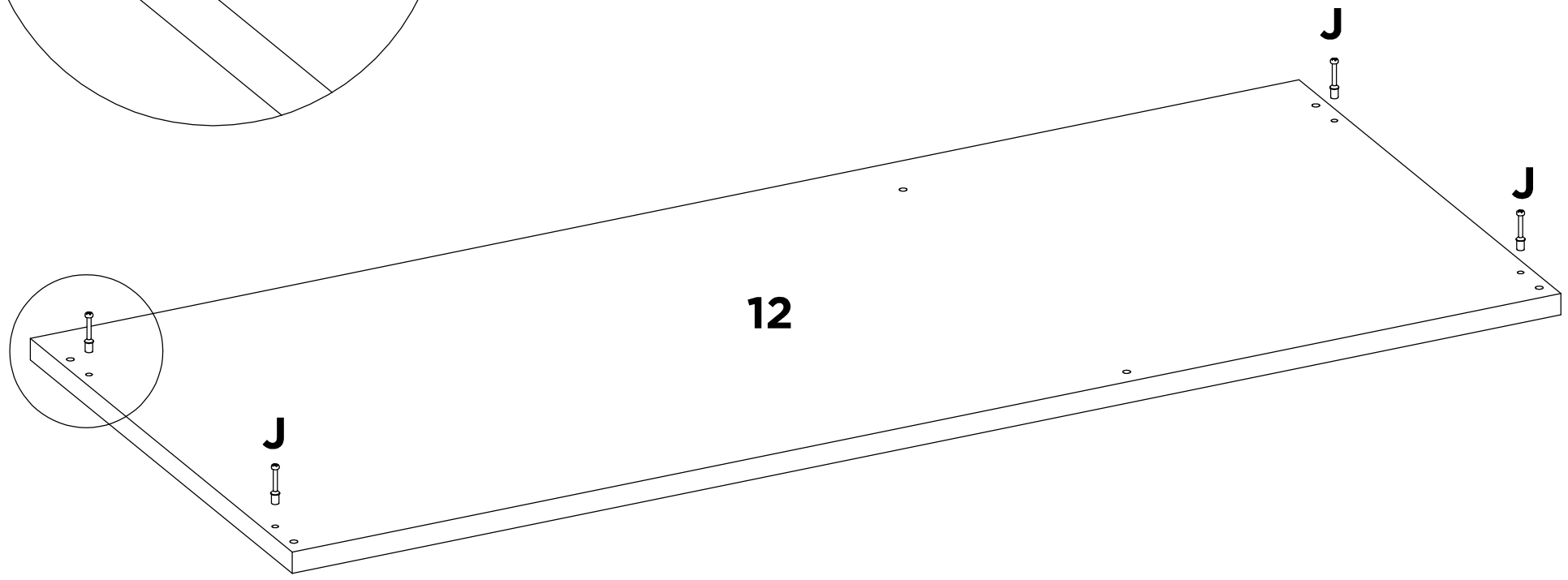
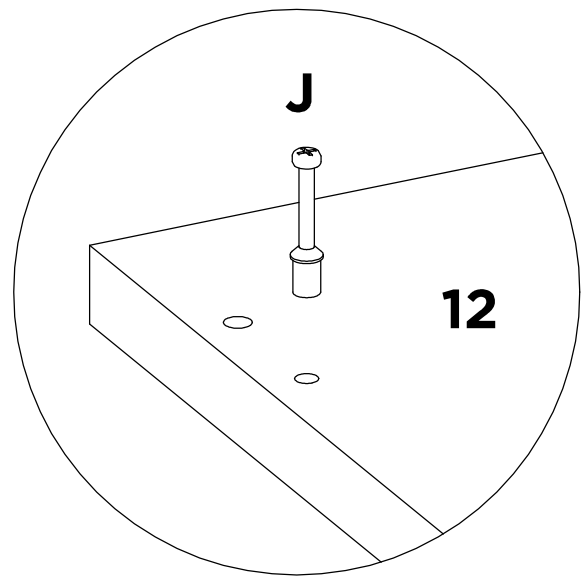

J
X4

-

-

-

-

-

-

-

09

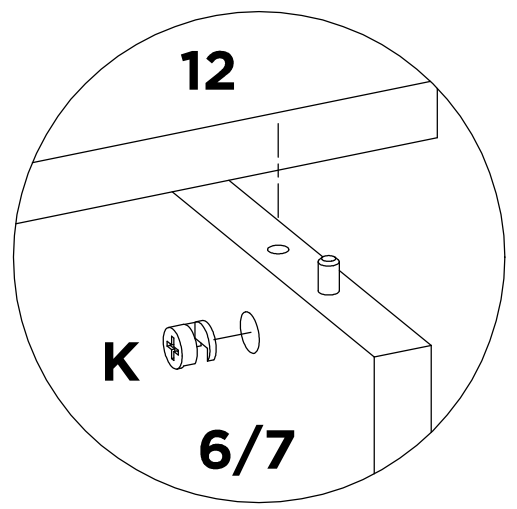
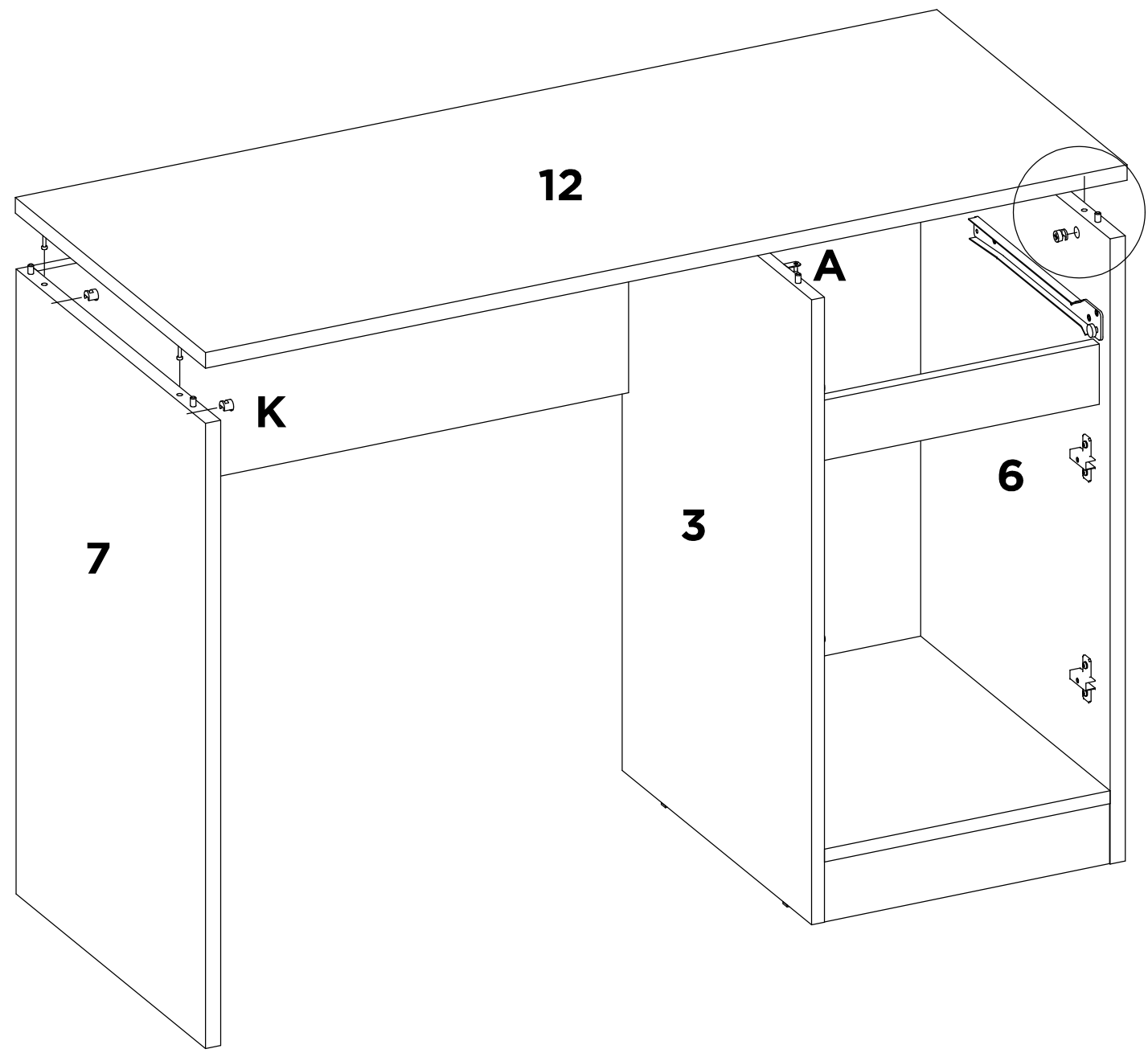

A	X2	K	X4	-	-	-	-	-	-
----------	-----------	----------	-----------	---	---	---	---	---	---

10

X

X

X



X

13

X

X

X

X



X



X

X

X20

-

-

-

-

-

-

-

-

-

-

-

-

-

-

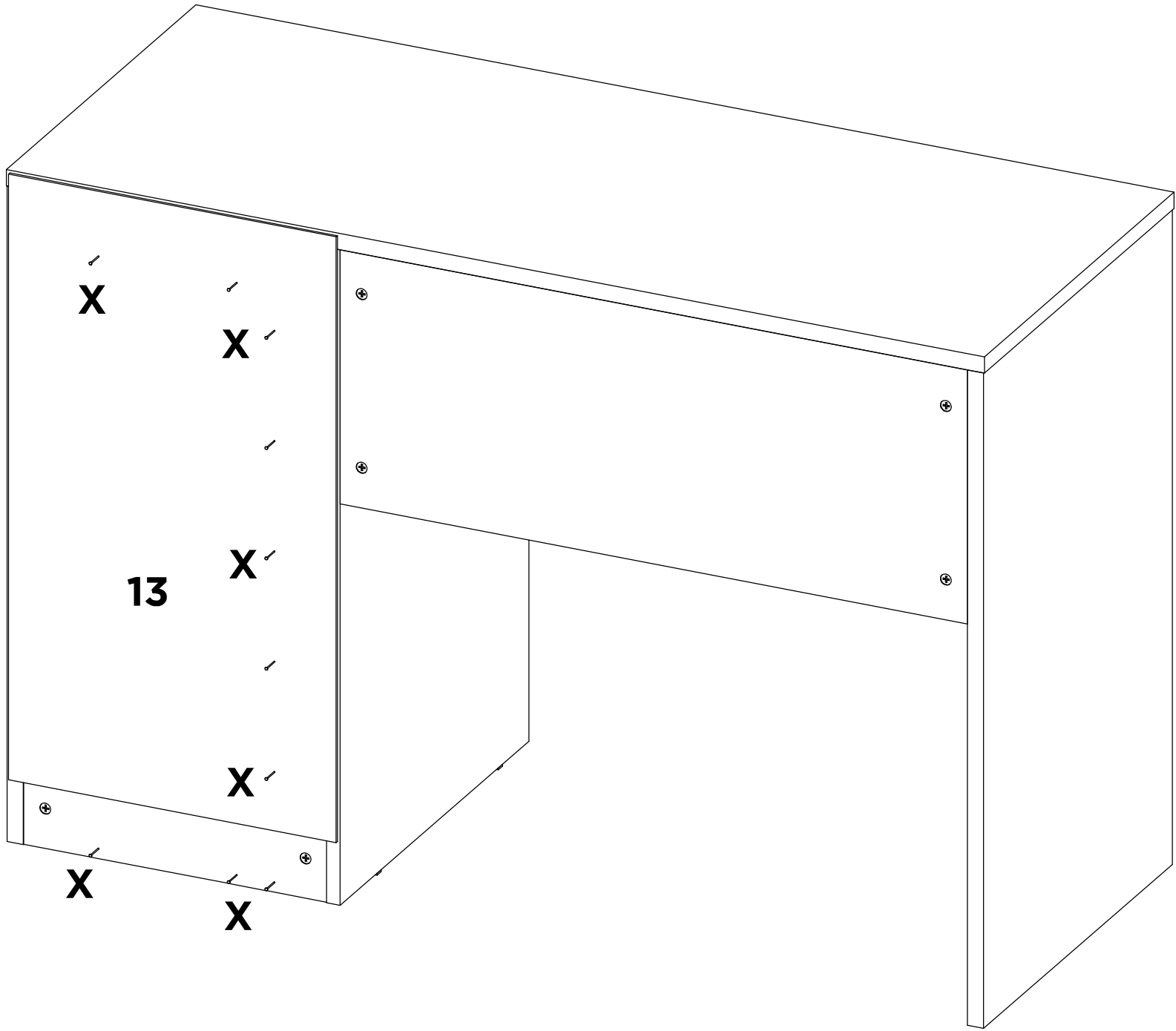

X	-	-	-	-	-	-	-
X20	-	-	-	-	-	-	-

11

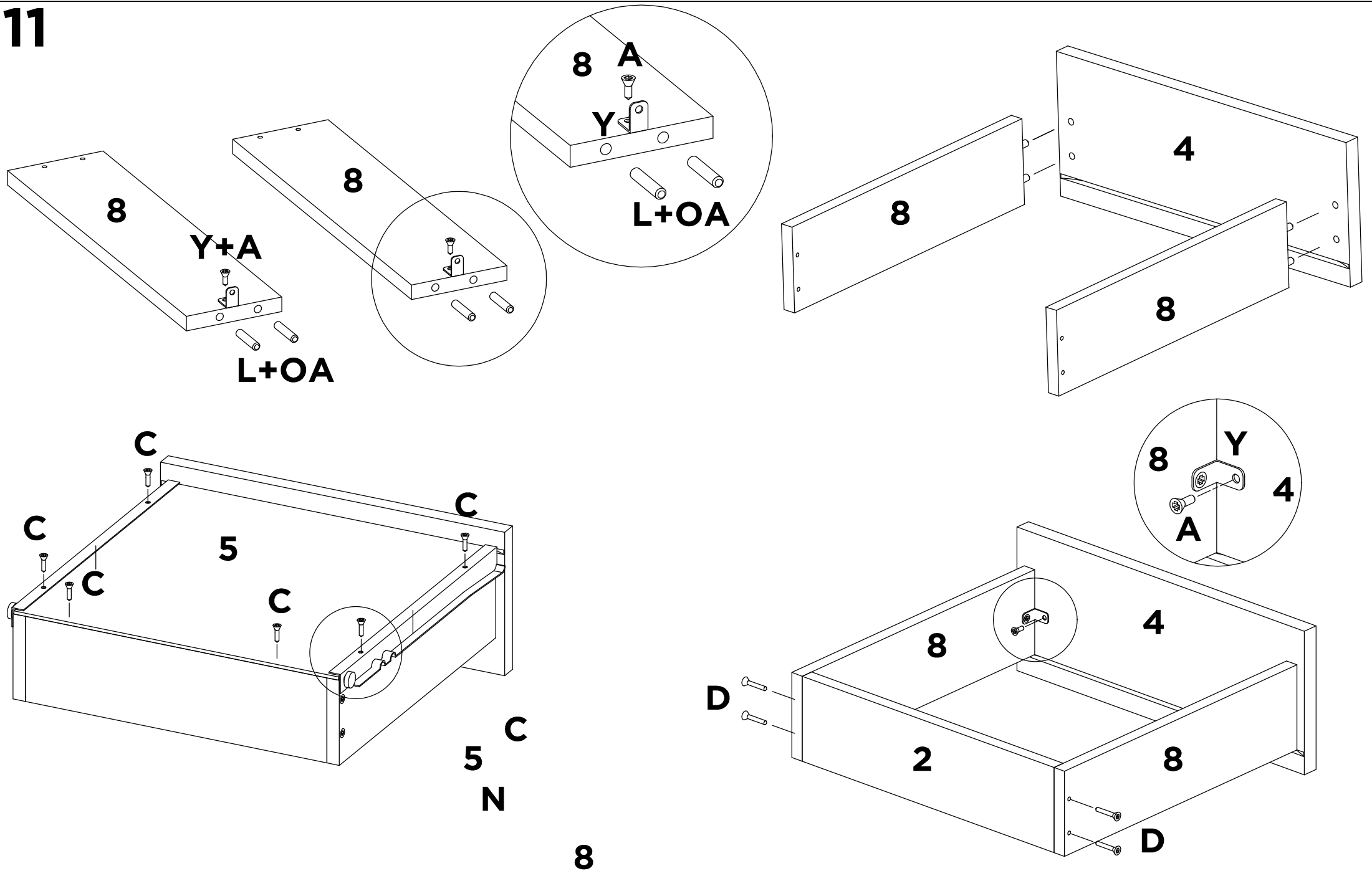

L	OA	A	Y	D	C	N	-
X4	X1	X4	X2	X4	X6	X1	-

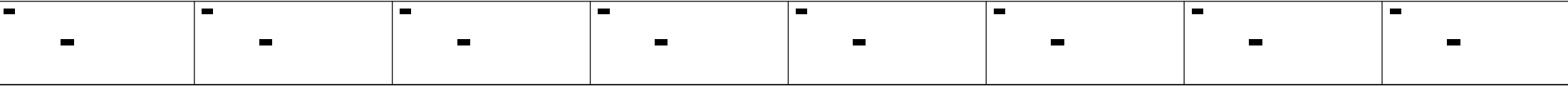
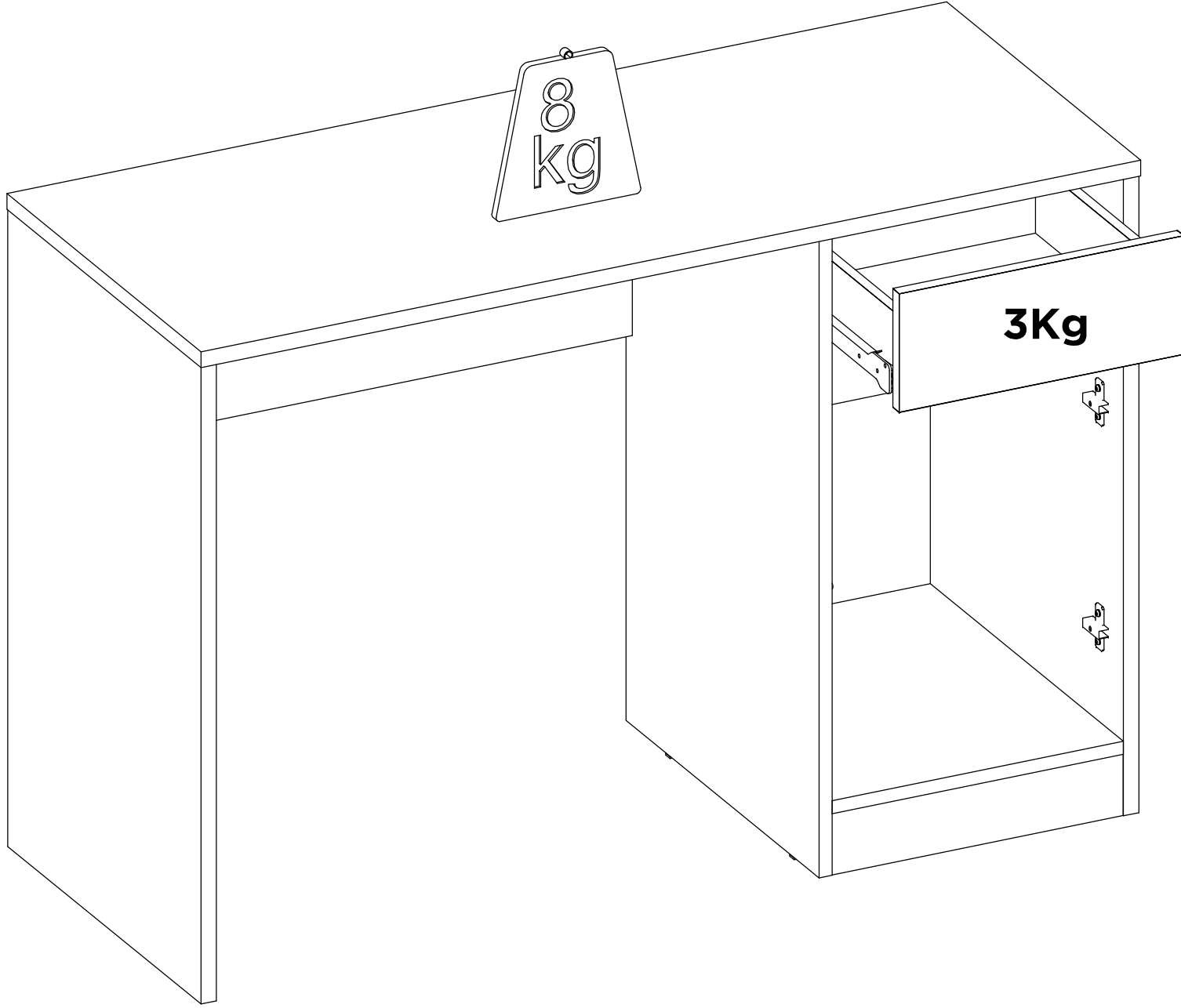

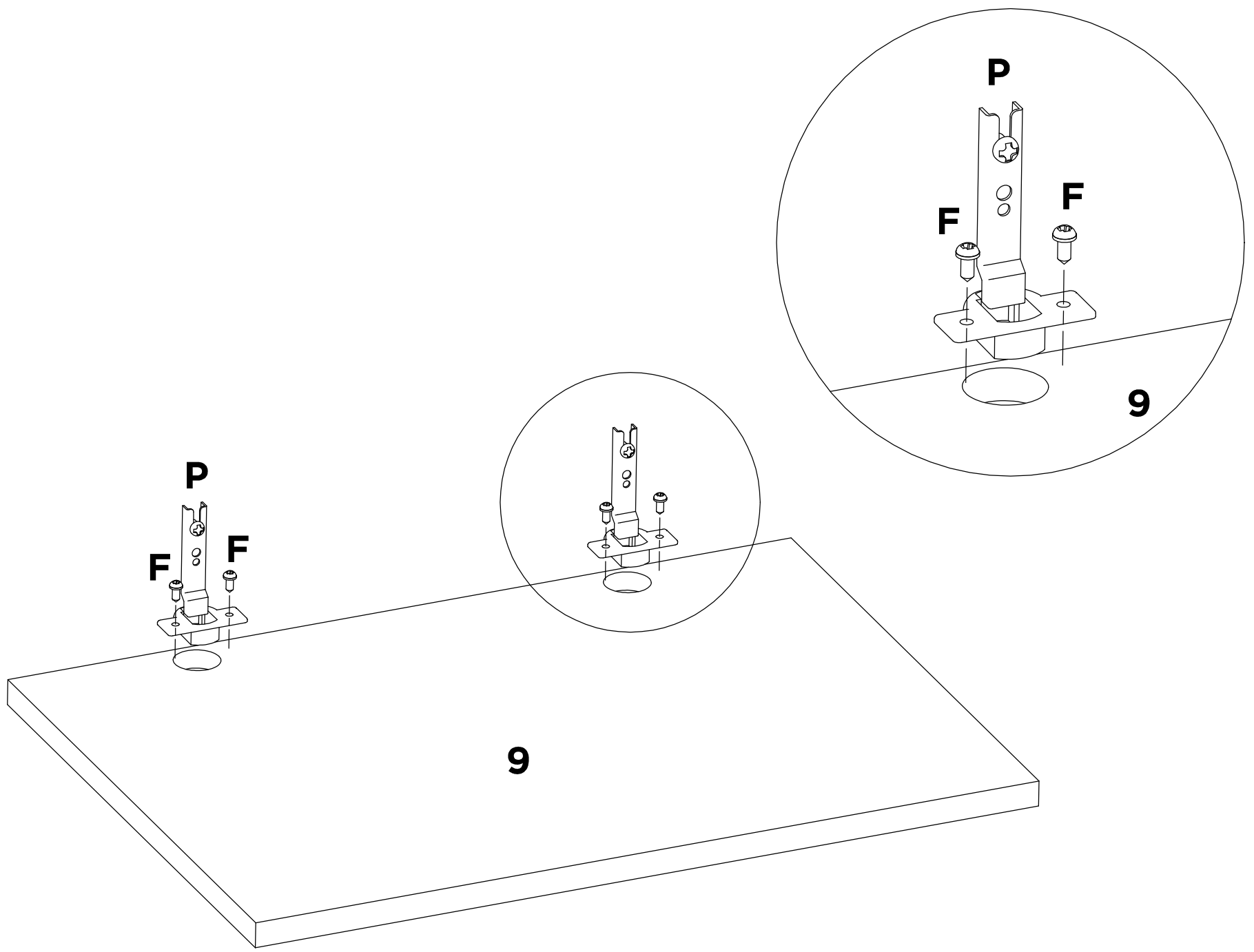

P	X2	F	X4	-	-	-	-	-	-
----------	-----------	----------	-----------	---	---	---	---	---	---

