

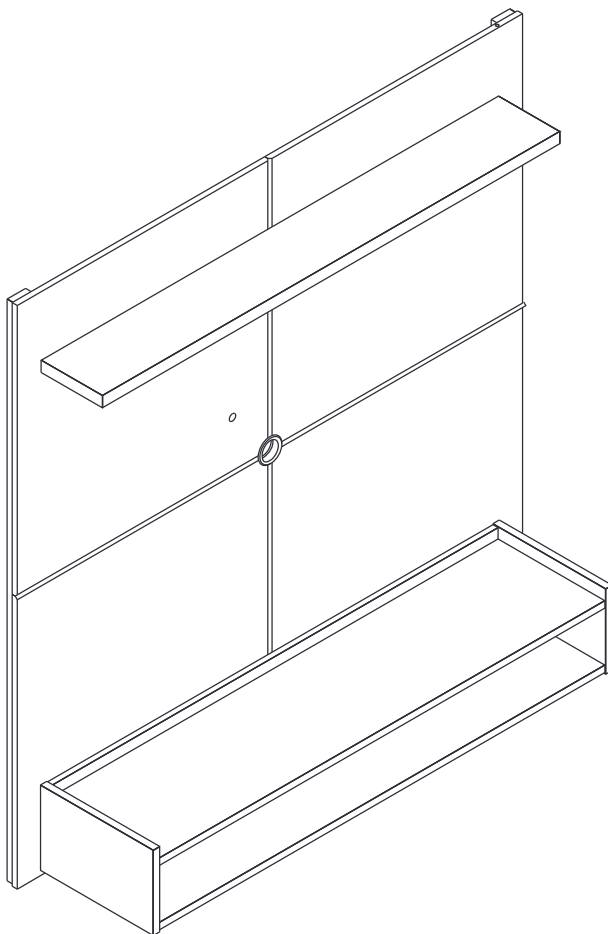

Linea Brasil



PAINEL HOME CRETA

V-3 16/11/23

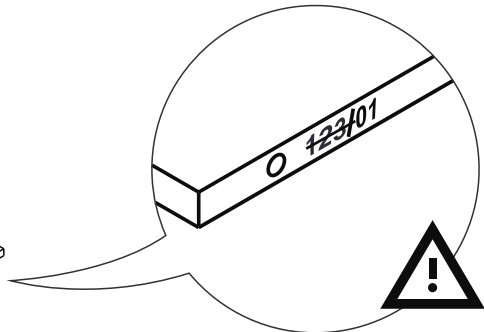
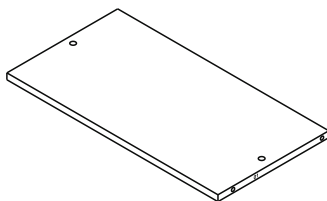
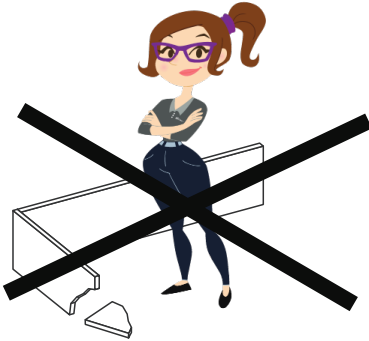
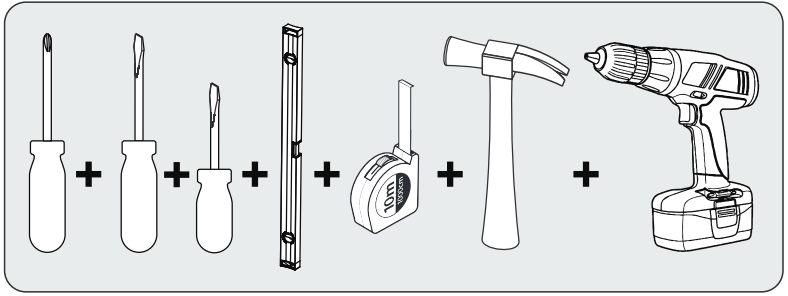
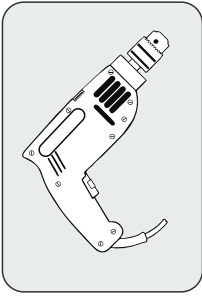

GARANTIA / GARANTIA / WARRANTY

Nossos produtos são garantidos por 90 dias contra defeitos de fabricação. Ao constatar um problema coberto pela garantia, entre em contato com a loja onde o produto foi comprado. Ela estará capacitada para atendê-lo da melhor forma diante de cada caso. Reclamações de garantia somente poderão ser atendidas se o termo de garantia for apresentado no ato de reivindicação, acompanhado de sua nota fiscal de compra.

Nuestros productos están garantidos contra defectos de fabricación por 90 días, a partir de la compra. Ao constatar un problema protegido por la garantía, póngase en contacto con la tienda donde se adquirió el producto. Ella estará capacitada para atenderlo de la mejor manera de acuerdo con cada caso.

Our products are guaranteed against manufacturing defects for 90 days from the date of purchase. When you find a problem covered by the warranty, please contact the store where the product was purchased. The store is able to serve you in the best way in each case.

Exclusões

- Desgaste natural ou danos causados por água, maresia, ferrugem, incêndio, calor, cupins e pragas em geral.
- Montagem, manutenção e uso inadequado.
- Não cumprimento das recomendações técnicas do esquema.
- Montagens e desmontagens após a primeira instalação.
- Instalações elétricas e outras afins.

Exclusiones

- Desgaste natural o daños causados por agua, maresia, incendios, calor, termitas y plagas en general.
- Montaje, mantenimiento y uso inadecuado.
- No cumplimiento de las recomendaciones técnicas del esquema.
- Montaje y desmontaje después de la primera instalación.
- Instalaciones eléctricas y otras afines.

Exclusions

- Natural wear or damage caused by water, sea, rust, fire, heat, termites and plagues in general.
- Assembly, maintenance and improper use.
- Failure to comply with the technical recommendations of the assembly instructions.
- Assembly and disassembly after first installation.

Importante

A Linha Brasil não autoriza nenhuma pessoa, loja ou entidade assumir em seu nome qualquer outra garantia que não conste no certificado. A fabricante reserva-se no direito de efetuar nos produtos eventuais modificações que considerar necessárias, sem prejudicar as características essenciais. Os produtos terão peças de assistência para reposição no período de 1 ano a contar de sua retirada do mercado, desde que haja matéria-prima equivalente, observando o dispositivo no Art.32 da Lei 8.078/90 (Cód. Defesa do Consumidor). O atendimento para produtos fora de linha é feito por programação especial, através da loja revendedora sob aprovação de consulta prévia ao fabricante.

Importante

Linea Brasil no autoriza a ninguna persona, tienda o entidad a asumir en su nombre cualquier otra garantía que no figure en el certificado. El fabricante se reserva el derecho de efectuar en los productos eventuales modificaciones que considere necesarias, sin perjudicar las características esenciales. Los productos tendrán piezas de asistencia para reposición en el periodo de 1 año a partir de su retirada del mercado. La atención para productos fuera de línea es hecha por programación especial, a través de la tienda revendedora bajo aprobación de consulta previa al fabricante.

Important

Linea Brasil does not authorize any person, store or entity to assume on its behalf any other warranty that does not appear on the certificate. The manufacturer reserves the right to make in the products any modifications that it considers necessary without prejudice to the essential characteristics. The products will have replacement parts within one year of being withdrawn from the market. The service for off-line products is done by special programming, through the store reseller under prior consultation with the manufacturer.

INSTRUÇÕES DE LIMPEZA E CONSERVAÇÃO

INSTRUCCIONES PARA LA LIMPIEZA E CONSERVACION / CLEAN AND PRESERVATION INSTRUCTURE

Para retirar o pó, utilize um pano seco, espanador ou aspirador. Se necessário, para uma limpeza mais efetiva, utilize um pano levemente umedecido com água. Finalize com uma flanela limpa e seca.

Para eliminar el polvo, utilice un paño seco, mopa o la aspiradora. Si es necesario, para una limpieza más eficaz, utilice un paño ligeramente humedecido con agua. Terminar con un paño limpio y seco.

To take dirty, use a dry cloth, duster or vacuum. If necessary to take the dust, use a wet cloth. Finish with a clean and dry flannel.

IMPORTANTE / IMPORTANTE / IMPORTANT



Não utilize produtos abrasivos como álcool e detergentes, como também esponjas rígidas ou palha de aço na limpeza dos móveis. No use limpiadores abrasivos como alcohol y detergentes, así como esponjas rígidas o lana de acero para limpiar los muebles. Do not use abrasives such as alcohol and detergent, tough soaker also steel wool to clean the furniture.



Proteja a superfície do móvel de objetos que transmitam calor ou umidade. Proteja la superficie del mueble de objetos que transmitan calor o humedad. Protect the surface of the furniture against objects that can pass heat and humidity.



Evitar o contato de água e produto de limpeza com o rodapé do produto, pois poderá danificá-lo. Evitar el contacto con agua y producto de limpieza con el rodapé del producto, pues poderá dañarlo. Avoid the contact of water and cleaning products with baseboard, cause it should damage your product.



Procure sempre utilizar flanela limpa e seca para a limpeza. Busque siempre utilizar flanela limpia y seca para la limpieza. Try always to use a clean and dry flannel to cleaning.



Cuidado com objetos pontiagudos, eles podem arranhar a superfície das portas e tampo. Cuidado con objetos afilados, ellos pueden rayar la superficie de las puertas e la tapa. Take care with sharp objects, they can scratch the door lid surface.

INSTRUÇÃO DE INSTALAÇÃO DE TELEVISORES

INSTRUCCIÓN DE INSTALACIÓN DE TELEVISIÓN / TELEVISION INSTALLATION INSTRUCTION

Para o uso do maior televisor indicado recomendamos a instalação da TV no painel do produto.

Para utilizar el televisor más grande indicado, recomendamos la instalación del televisor en el panel del producto.

To use the largest television indicated, we recommend installing the TV on the product panel.

TAMANHO DE TV SUGERIDO

TAMANO DE TELEVISOR SUGERIDO
SUGGESTED TV SIZE

50"

Imagem Ilustrativa/ Illustrative Image/ Imagen Ilustrativa

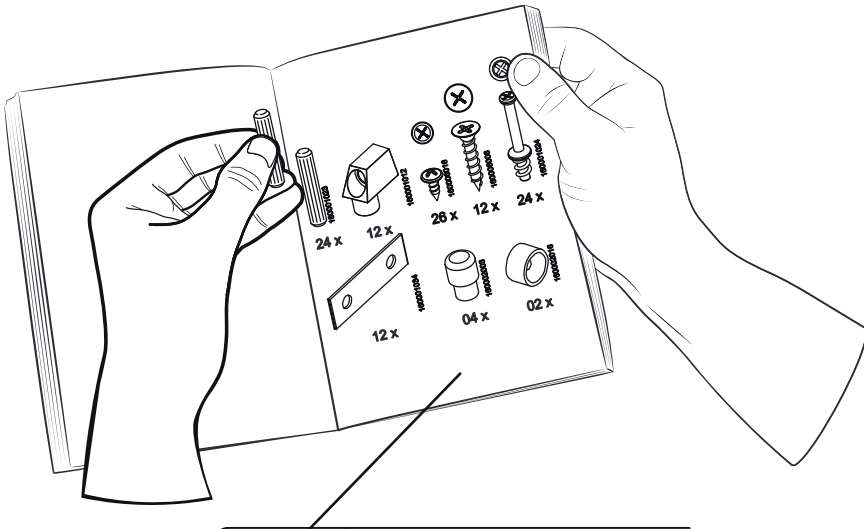

Preste Atenção! ¡Preste atención! Attention!



As ferragens dos nossos manuais são sempre apresentadas nas mesmas proporções da peça na vida real. Caso apareça alguma dúvida no decorrer do processo de montagem, coloque a ferragem ao lado do desenho e faça a consulta :D

Los accesorios de nuestros manuales siempre se presentan en las mismas proporciones que la pieza en la vida real. Si tiene alguna duda durante el proceso de montaje, coloque los accesorios junto al dibujo y haga una consulta :D

The accessories in our manuals are always presented in the same proportions as the spare part in real life. If you have any questions during the assembly process, place the accessory next to the drawing and make an inquiry :D

Símbolos: Símbolos: Symbols:



- + Parafuso Phillips
- Parafuso Fenda
- ⊙ Parafuso Allen
- + Tornillo Phillips
- Tornillo Ranurado
- ⊙ Tornillo Allen
- + Phillips screw
- Slotted Screw
- ⊙ Allenscrew



160001005

04x



160001009

04x

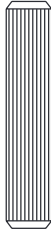

160001023

08x



160001024

04x

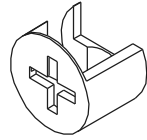

160001025

04x

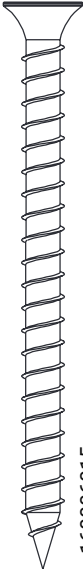

160006015

04x

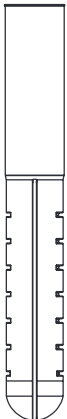

160002006

04x



160006010

06x



160006006

08x



160006018

16x



160006016

16x

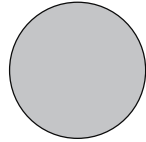

160002002

01x

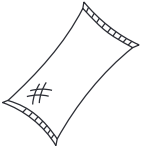

01x

160001001

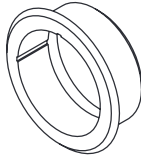

02x

160002005



02x

160002012

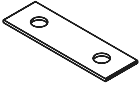

08x

160001034

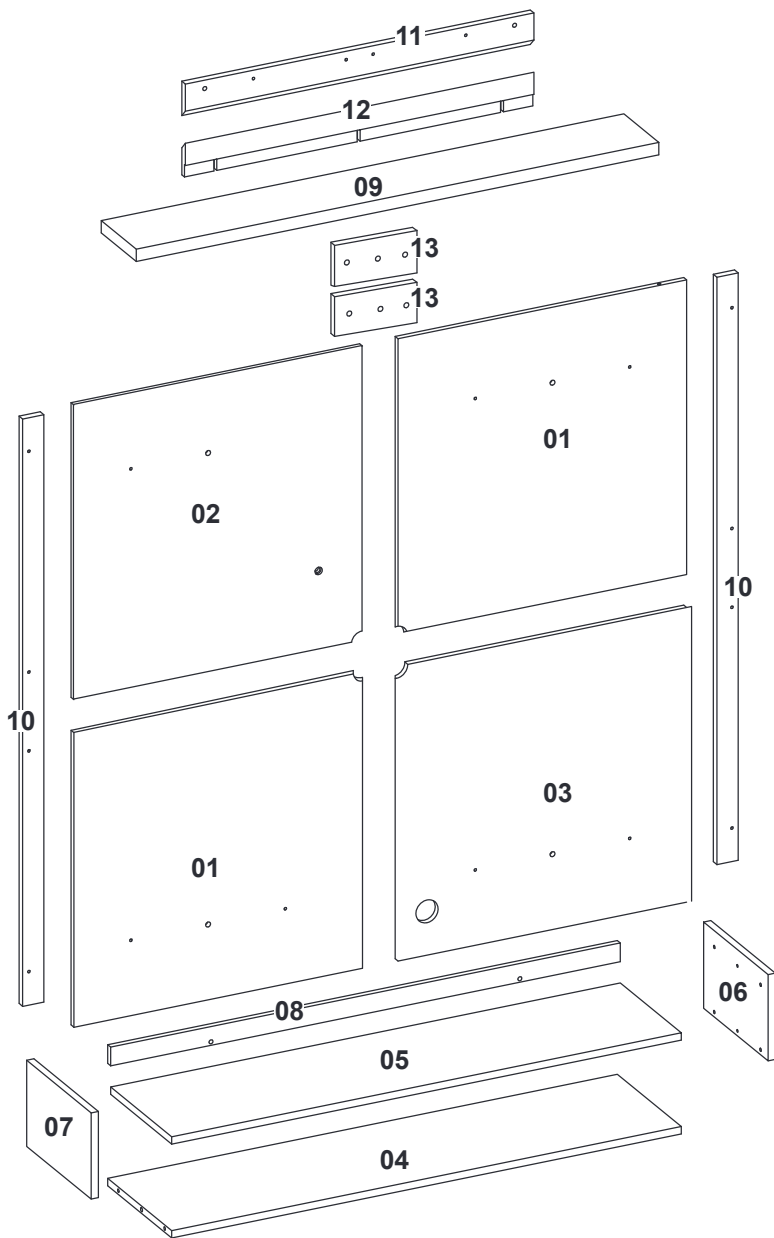

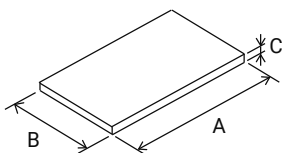

| VOLUME | ITEM | PEÇA | DESCRIÇÃO | DIMENSÕES (mm) | | | QUANTIDADE | MATERIAL |
|--------|----------|-----------|---|--------------------|-----|----|-------------|----------|
| | | | | Dimensão/Dimension | | | | |
| Caja | Artículo | Pieza | Descripción | A | B | C | La cantidad | |
| Box | Item | Part | Description | | | | The amount | |
| 1 | 1 | 510321001 | PAINEL SUPERIOR DIREITO / INFERIOR ESQUERDO | 598 | 598 | 12 | 2 | MDP |
| 1 | 2 | 510321002 | PAINEL SUPERIOR ESQUERDO | 598 | 598 | 12 | 1 | MDP |
| 1 | 3 | 510321003 | PAINEL INFERIOR DIREITO | 598 | 598 | 12 | 1 | MDP |
| 1 | 4 | 510321004 | BASE | 1056 | 265 | 15 | 1 | MDP |
| 1 | 5 | 510321005 | TAMPO | 1056 | 253 | 15 | 1 | MDP |
| 1 | 6 | 510321006 | LATERAL DIREITA | 267 | 175 | 15 | 1 | MDP |
| 1 | 7 | 510321007 | LATERAL ESQUERDA | 267 | 175 | 15 | 1 | MDP |
| 1 | 8 | 510321008 | ENCABECAMENTO | 1056 | 38 | 12 | 1 | MDP |
| 1 | 9 | 510321009 | PRATELEIRA | 1083 | 145 | 25 | 1 | MDP |
| 1 | 10 | 510321010 | TRAVESSA LATERAL | 1192 | 44 | 15 | 2 | MDP |
| 1 | 11 | 510321011 | TRAVESSA PAINEL | 722 | 70 | 15 | 1 | MDP |
| 1 | 12 | 510321012 | TRAVESSA PAREDE | 722 | 70 | 15 | 1 | MDP |
| 1 | 13 | 510321013 | TRAVESSA APOIO | 160 | 70 | 15 | 2 | MDP |

| ARTÍCULO | DESCRIPCIÓN |
|----------|--------------------------------------|
| 1 | PANEL SUPERIOR DERE. / INFERIOR IZQ. |
| 2 | PANEL SUPERIOR IZQUIERDO |
| 3 | PANEL INFERIOR DERECHO |
| 4 | BASE |
| 5 | BASE TV |
| 6 | LATERAL DERECHA |
| 7 | LATERAL IZQUIERDA |
| 8 | ENCABEZAMIENTO |
| 9 | REPISA |
| 10 | TRAVESAÑO LATERAL |
| 11 | TRAVESAÑO DEL PANEL |
| 12 | TRAVESAÑO DE LA PARED |
| 13 | TRAVESAÑO DE APOYO |

| ITEM | DESCRIPTION |
|------|-------------------------------|
| 1 | TOP RIGHT / BOTTOM LEFT PANEL |
| 2 | TOP LEFT PANEL |
| 3 | RIGHT BOTTOM PANEL |
| 4 | BASE |
| 5 | TV BASE |
| 6 | RIGHT SIDE |
| 7 | LEFT SIDE |
| 8 | FRAME |
| 9 | SHELF |
| 10 | LATERAL CROSSBAR |
| 11 | PANEL CROSSBAR |
| 12 | WALL CROSSBAR |
| 13 | SUPPORT CROSSBAR |

01

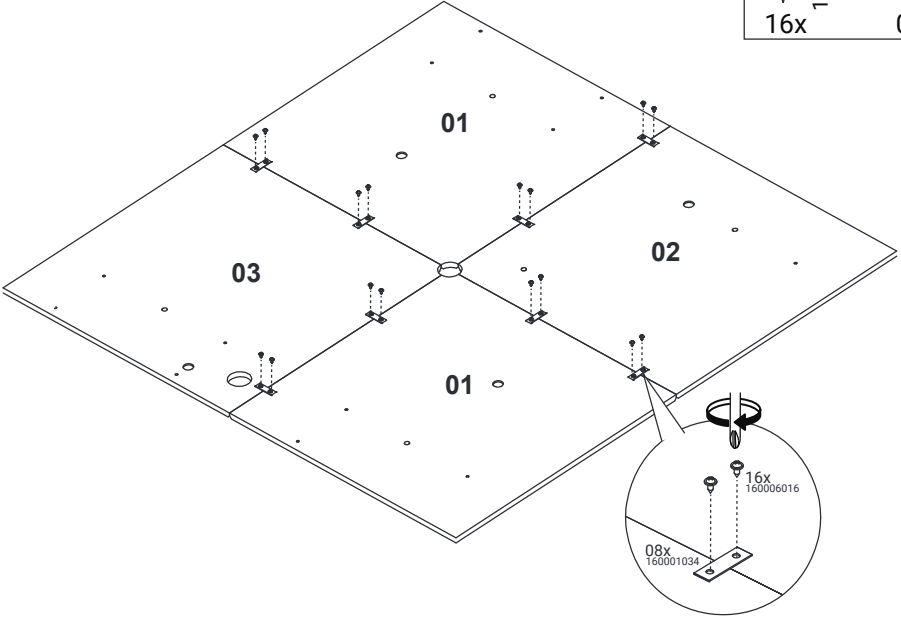
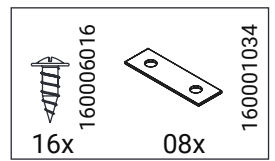

02

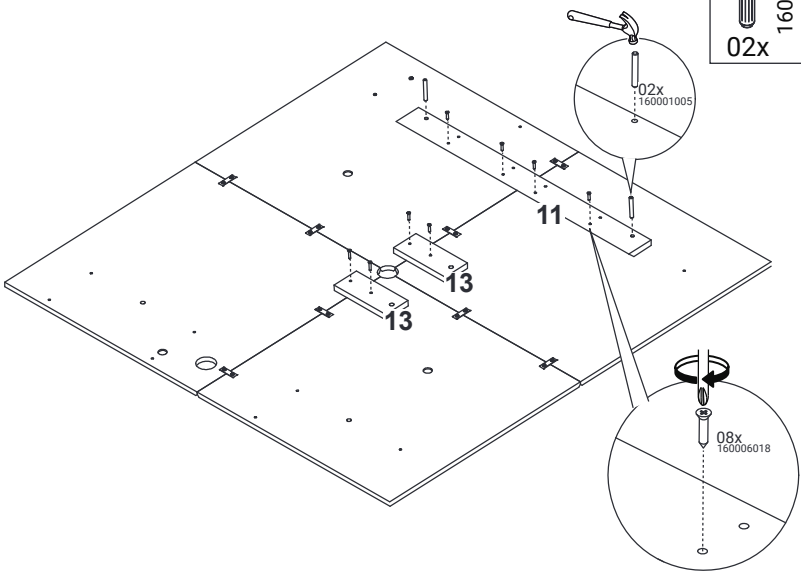
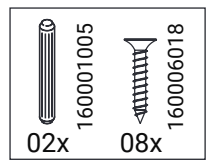

03

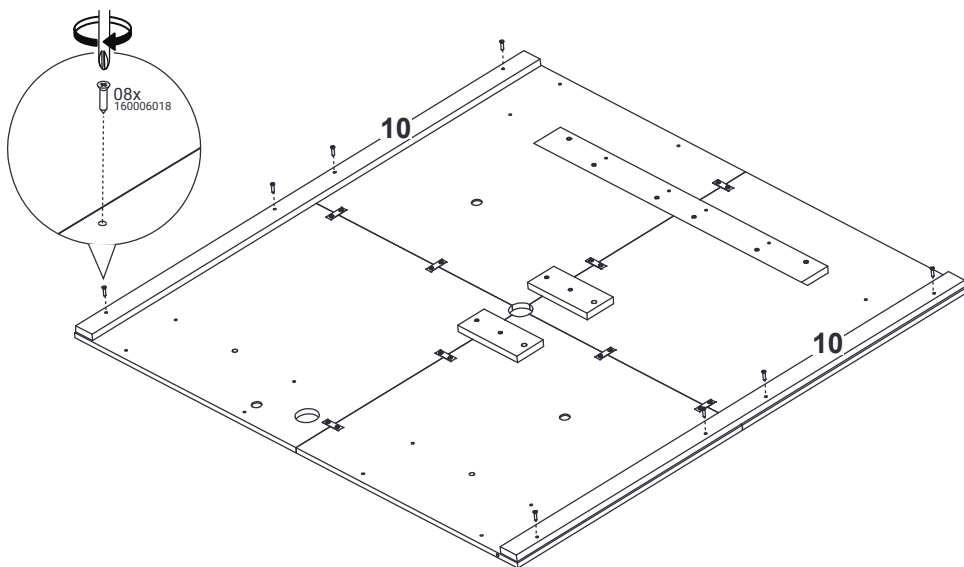
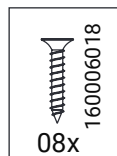

04

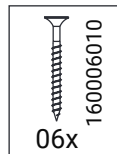
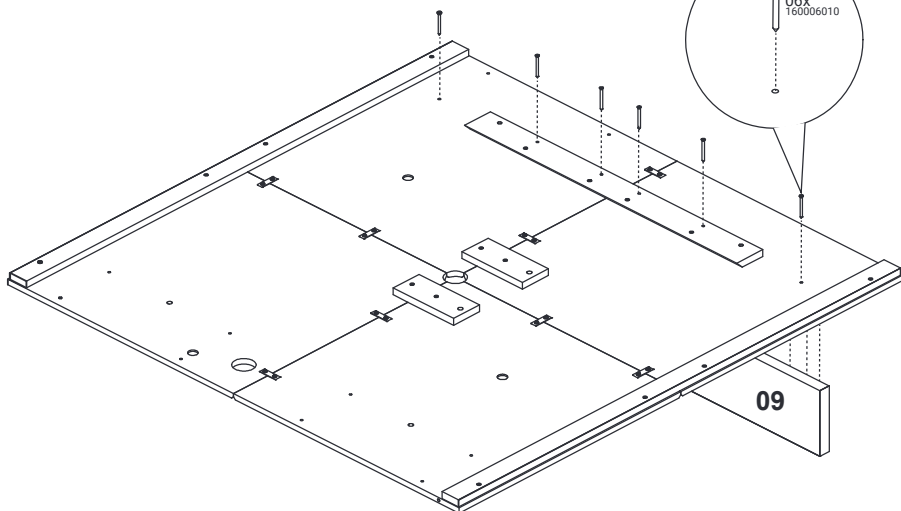

05

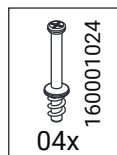
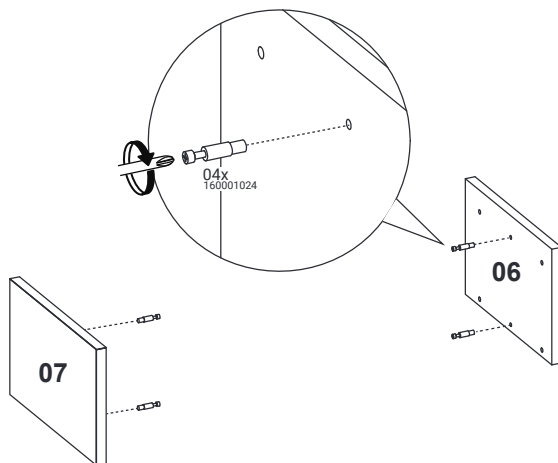

06

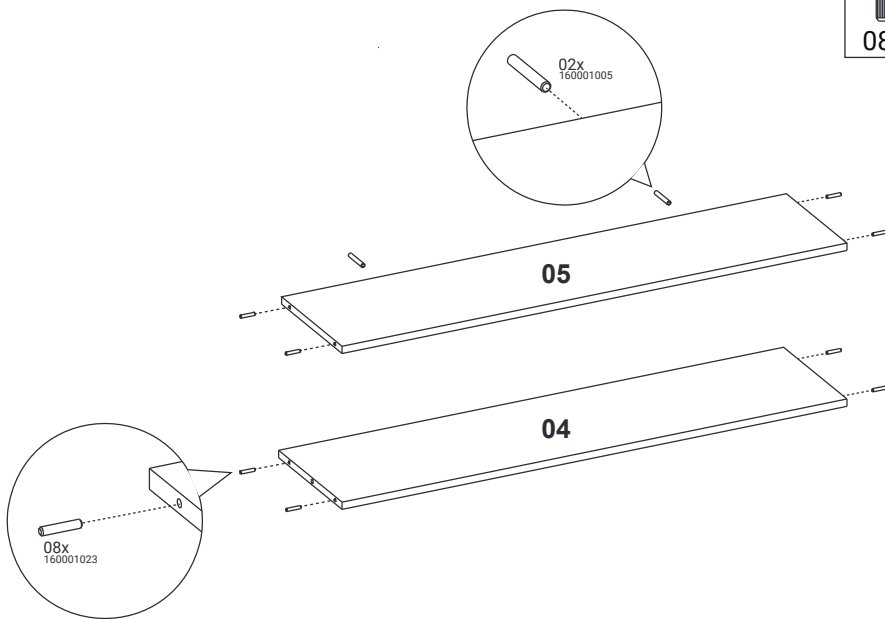
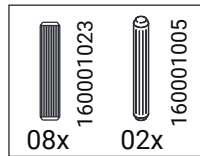

07

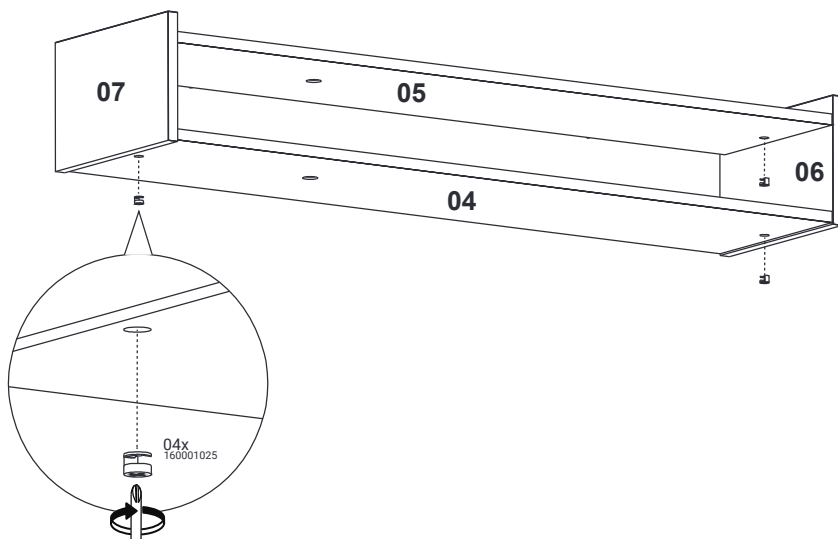
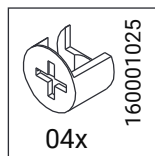
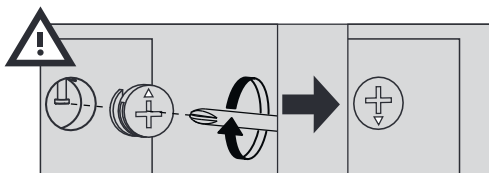

08

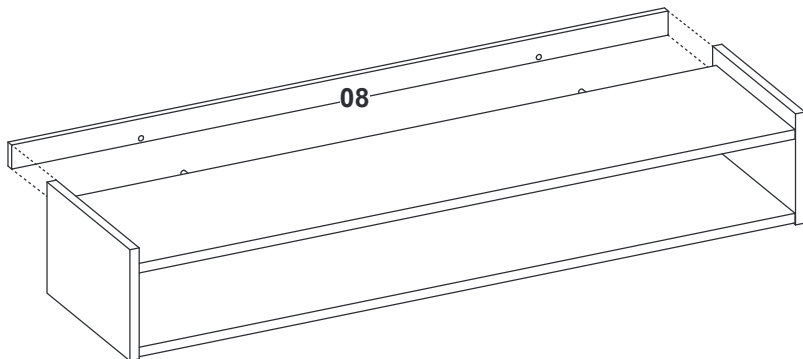

09

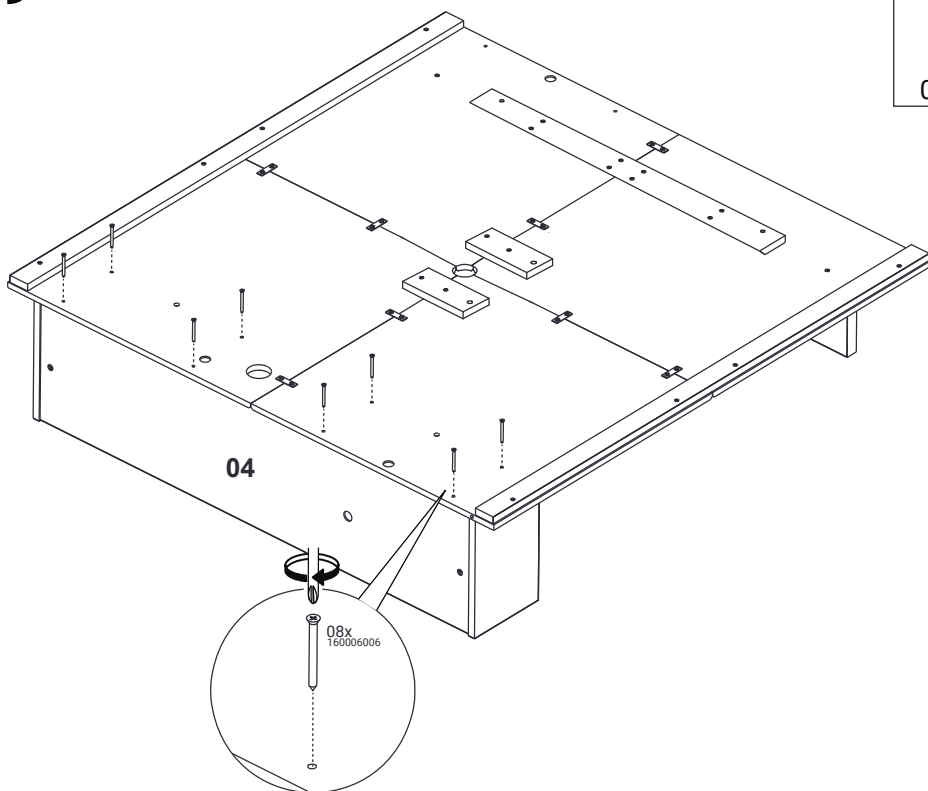

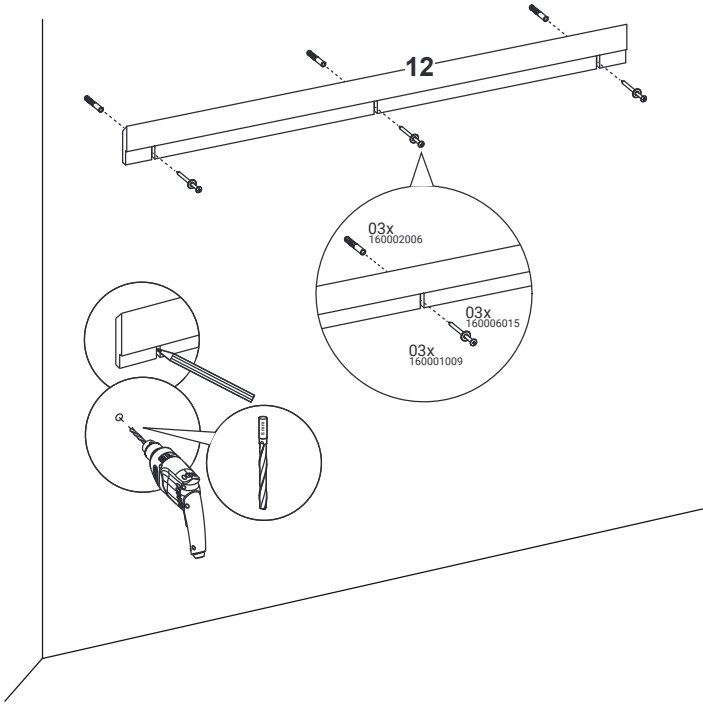
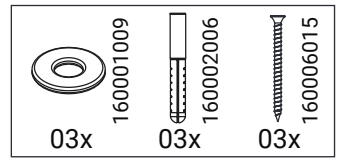

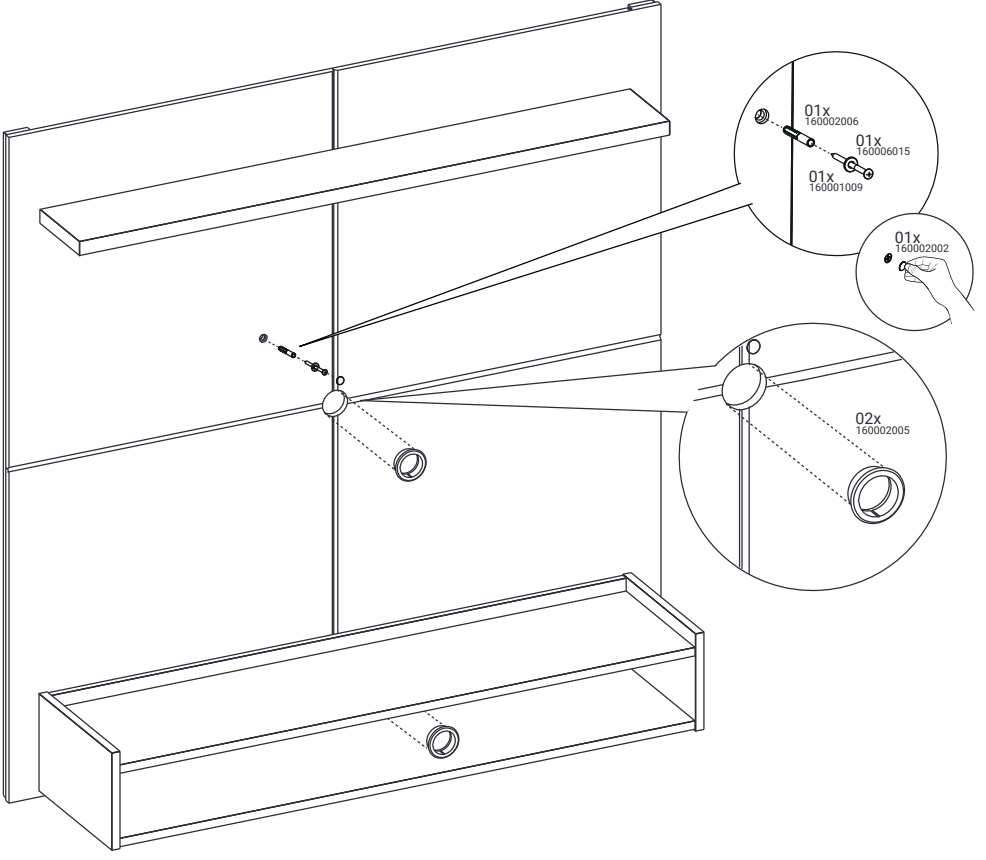
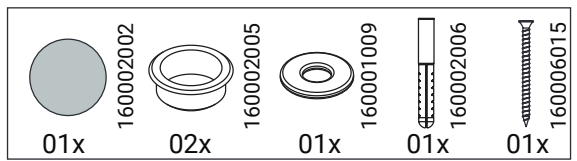

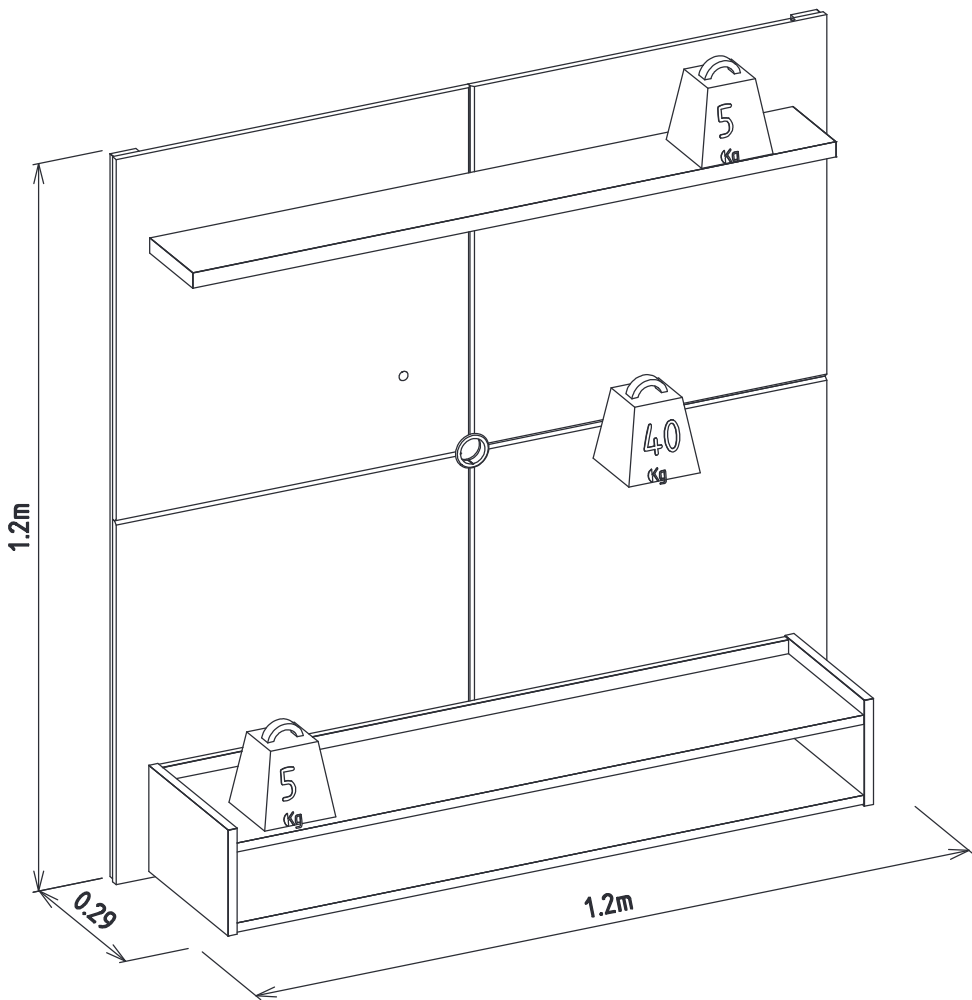

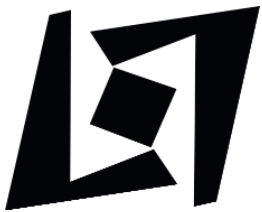

Linea Brasil