



Barreto Lonçarcci Indústria de Móveis LTDA
 Acesso Antônio Pimentel, 160, Marginal 2 - DIST. INDUSTRIAL.
 VALENTIM GENTIL - SP - CEP: 15.520-000
 TEL.: (17) 3404 - 1010
 E-MAIL: contato@barretoloncarcci.com.br - www.barretoloncarcci.com.br

INSTRUÇÃO DE MONTAGEM MÓVEL DE CABECEIRA - CAIRO



DIMENSÕES DO PRODUTO

COMPRIMENTO: 376 mm
 LARGURA: 428 mm
 ALTURA: 625 mm

Ferramentas necessárias (não fornecidas)

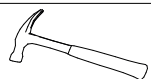

Martelo

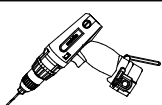

Parafusadeira



Chave de Fenda/ Phillip

ATENÇÃO:

- 1 - Ler e observar toda a instrução de montagem antes de iniciar a montagem.
 - 2 - A montagem do produto deverá ser feita em uma superfície limpa e plana. Aconselhamos usar a embalagem para forrar o chão a fim de não danificar o produto.
 - 3 - Os parafusos devem ser apertados periodicamente.
 - 4 - Evitar batidas e contatos com objetos cortantes.
- LIMPEZA**
- 1 - Pano levemente umedecido com água, seguido de pano seco.
 - 2 - Não utilizar produtos químicos ou abrasivos.

Nota: Garantia para defeito de fábrica conforme Lei Nº 8.078, Artigo 26 do Código do consumidor

RELAÇÃO DE PEÇAS

COD.	DESCRIÇÃO	MATERIAL	QTD.	COMPRIMENTO	LARGURA	ESPESSURA
01	Lateral Direita	MDF	01	540mm	358mm	12mm
02	Lateral Esquerda	MDF	01	540mm	358mm	12mm
03	Vista Superior	MDF	01	380mm	40mm	12mm
04	Vista Inferior	MDF	01	380mm	40mm	20mm
05	Vista Lateral	MDF	02	338mm	40mm	15mm
06	Tampo	MDF	01	428mm	378mm	20mm
07	Prateleira	MDF	01	364mm	357mm	12mm
08	Base	MDF	01	364mm	357mm	12mm
09	Fundo Traseiro	MDF	01	555mm	384mm	03mm
10	Frente da Gaveta	MDF	01	372mm	162mm	12mm
11	Contra Fundo da Gaveta	MDF	01	315mm	90mm	12mm
12	Fundo da Gaveta	MDF	01	306mm	327mm	03mm
13	Lateral Direita da Gaveta	MDF	01	300mm	110mm	12mm
14	Lateral Esquerda da Gaveta	MDF	01	300mm	110mm	12mm
15	Moldura Lateral	MDF	02	557mm	40mm	20mm
16	Pés de Madeira	MDF	04	65mm	45mm	45mm

ACESSÓRIOS E FERRAGENS

<p>A 01 Par Corrediça Telescópica 350mm</p>	<p>B 04x Pino Minifix 12mm</p>	<p>C 04x Tambor Minifix Ø12</p>	<p>D 30x Pregos 10x10 Com Cabeça</p>	<p>E 12x Parafuso 4,0x 25 Cabeça Chata</p>
<p>F 08x Parafuso 4,5 x 40 Cabeça Chata</p>	<p>G 04x Parafuso 3,5 x 30 Cabeça Chata</p>	<p>H 04x Cavilha Madeira 6,0 x 30</p>	<p>I 32x Parafuso 3,5 x 12 Cabeça Chata</p>	<p>J 01x Puxador MDF 220x40x15mm</p>
<p>K 04x Cantoneira Metálica 4 Furos</p>	<p>L 04x Parafuso 5,0 x 50 Cabeça Chata</p>	<p>M 01x Giz</p>	<p>Use a Escala (Régua) abaixo para medir os parafusos e acessórios. Coloque-os encima da escala para verificar o tamanho correto indicado.</p>	

Explodido Conheça as Peças

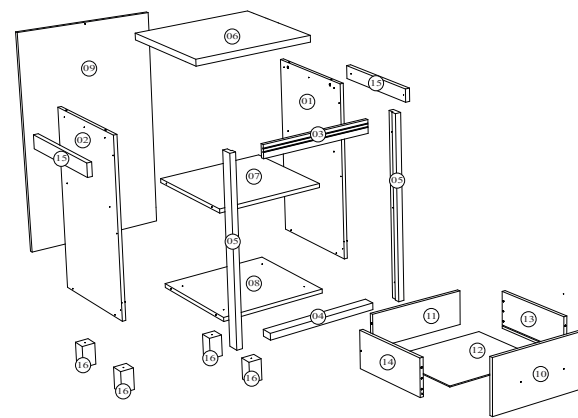

01 Lateral Direita

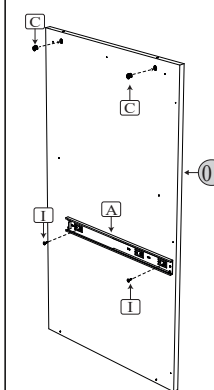

02 Lateral Esquerda

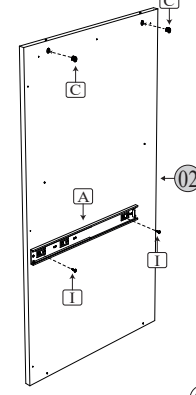

Preparação das Peças

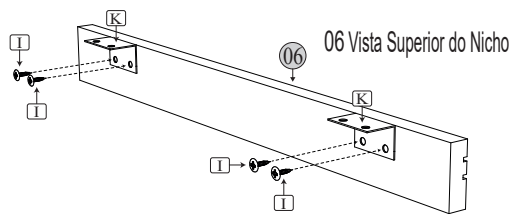
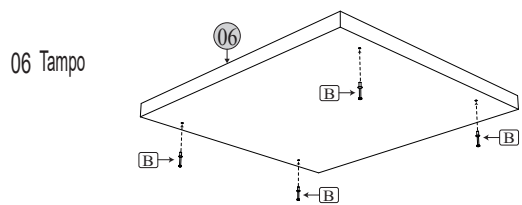

13 14 Lateral da Gaveta

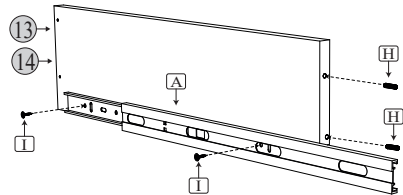

10 Frente da Gaveta

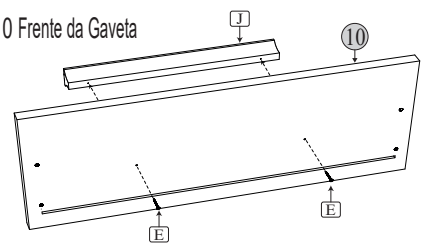

PASSO 01 | FIXANDO OS PÉS.

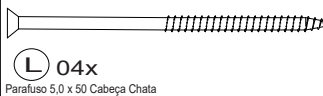
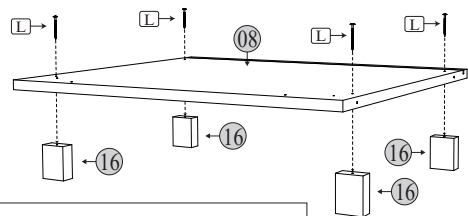

PASSO 02 | INSTALANDO A BASE E LATERAIS

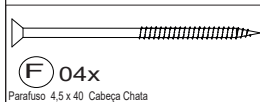
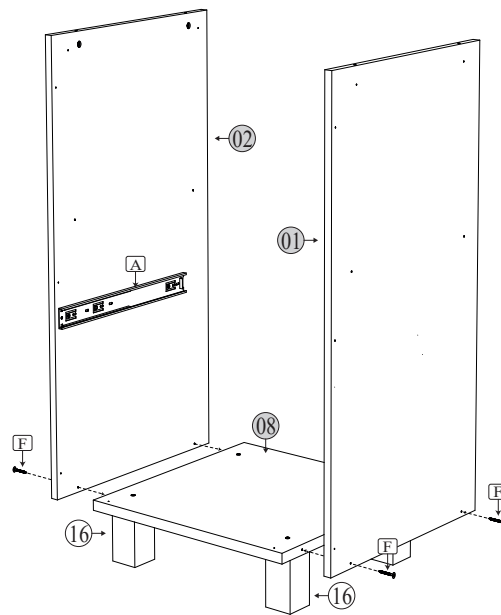

PASSO 05 | INSTALANDO A MOLDURA SUPERIOR

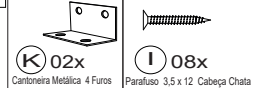
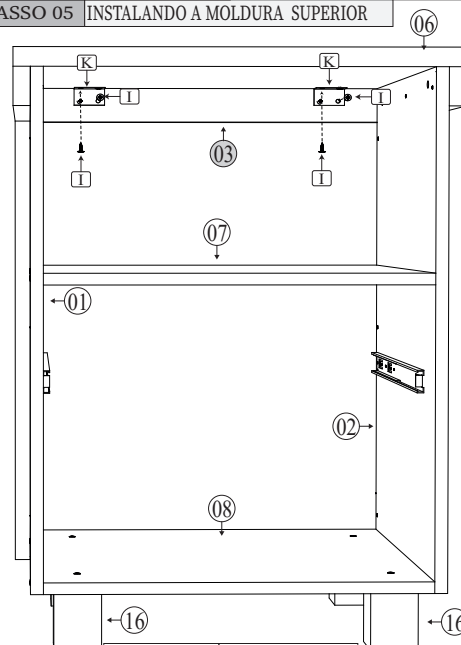

PASSO 03 | FIXANDO O TAMPO E PRATELEIRA

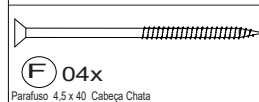
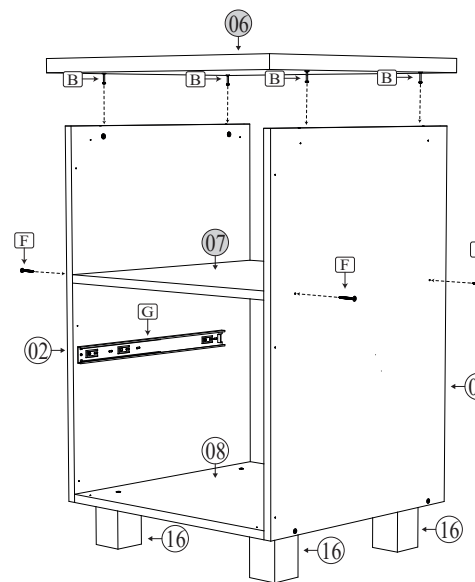

PASSO 06 | FIXANDO O FUNDO

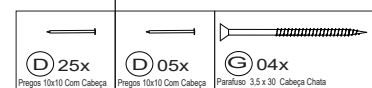
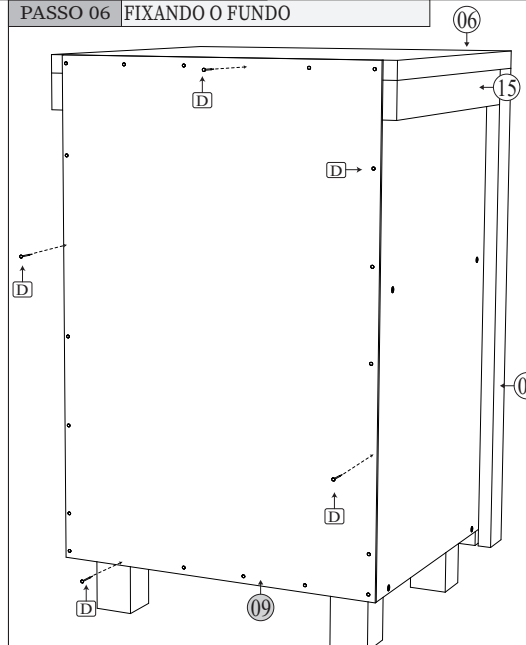

PASSO 04 | FIXANDO AS VISTAS

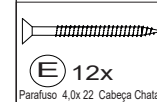
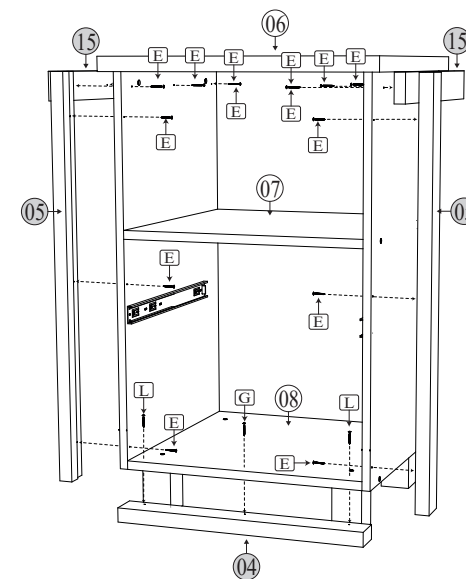

PASSO 07 | MONTANDO A GAVETA

